



INSTRUCTION AND MAINTENANCE MANUAL:

FP AND FPX Double Flange Style Pump

(For FP pumps with motor frame sizes 250TC through 400TC
and FPX pumps with motor frame sizes 280TC through 320TC)



SANITARY CENTRIFUGAL PUMPS



omd ■ 800-648-3326
oliver m. dean, inc. ■ www.omdean.com

DESCRIPTION

This manual contains installation, operation, assembly, disassembly and repair instructions for the Fristam FP and FPX double-flange style centrifugal pump.

The heavy-duty FP style pump is mounted on a pedestal-style flange support (except for the FP 4000 model, which is close coupled mounted). The flange support provides an extremely sturdy method of coupling the pump head and the motor. It absorbs vibrations and noise. The flange support also fastens the pump to the floor (or adjustable base). The FP series is available with either a single or double mechanical seal.

The general purpose FPX style pump is mounted on a close coupled-style flange support. The FPX series is only available with a single mechanical seal.

There are two general styles of pump heads in "F" type Fristam pumps. The 700 and 1700 series are non-volute style pumps. The 1050, 1150, 3400, 3500, 4000 series are volute style. In general, maintenance procedures for both series are generally the same. Any variations are clearly noted.

The motors used on both the FP and FPX style pumps are standard NEMA totally enclosed fan cooled (TEFC) motors. They are C-face (except 320TSD, which are D flange - only available on FP series pumps). Motors for the 4000 model are C-faced 320-400 TC only. Replacement motors are readily available from local motor distributors.

CAUTION: Begin all pump maintenance operations by disconnecting the energy source to the pump. Observe all lock out/tag out procedures as outlined by ANSI Z244.1-1982 and OSHA 1910.147 to prevent accidental start-up and injury.



TABLE OF CONTENTS

TECHNICAL INFORMATION.....	4
RECOMMENDED PREVENTIVE MAINTENANCE.....	5
SEAL REPLACEMENT (735 AND 736 SEAL SIZE)	6-11
PUMP DISASSEMBLY	6-7
PUMP ASSEMBLY	10-11
SINGLE SEAL ASSEMBLY DRAWING.....	8
DOUBLE SEAL ASSEMBLY DRAWING (FP SERIES ONLY)	9
SEAL REPLACEMENT (FP 4000 SERIES - 102 SEAL SIZE).....	12-16
PUMP DISASSEMBLY	12
PUMP ASSEMBLY	13-14
SINGLE SEAL ASSEMBLY DRAWING.....	15
DOUBLE SEAL ASSEMBLY DRAWING	16
PUMP SHAFT AND/OR MOTOR REPLACEMENT	17-19
PUMP DISASSEMBLY	17
ASSEMBLING MOTOR TO THE FLANGE SUPPORT	18
ASSEMBLING THE PUMP SHAFT TO THE MOTOR SHAFT.....	18
SETTING THE IMPELLER GAP.....	18-19
FP AND FPX DOUBLE FLANGE (735 AND 736 SEAL SIZE) EXPLODED VIEW	20-21
FP DOUBLE FLANGE (FP 4000 SERIES - 102 SEAL SIZE) EXPLODED VIEW	22-23
INSTALLATION	24-25
ELECTRICAL INSTALLATION.....	25
PUMP OPERATIONS	26
INSTALLATION OF WATER FLUSH FOR DOUBLE MECHANICAL SEAL.....	26
TROUBLESHOOTING.....	27-29
NOTICE OF TERMS, WARRANTY PROVISIONS INCLUDING DISCLAIMERS, CLAIMS AND LIMITATION OF LIABILITY.....	31

TECHNICAL INFORMATION

SPECIFICATIONS

Maximum Inlet Pressure	150 PSI
Temperature Range	-40°F - 400°F
Noise Level.....	60 - 85 dB(A)

MATERIALS OF CONSTRUCTION

Primary Product Contact Components	AISI 316L
Cover Gasket.....	BUNA (standard)
Also available in	others available upon request
Surface Finish for Product Contact Surfaces	32 Ra (standard) - other finishes available

SHAFT SEALS

FP Mechanical Seal Type	Single or Double Internal
Seal Flush Water Pressure (double seal only)	5 PSI Max.
Seal Water Consumption (double seal only)	1-2 gph
FPX Mechanical Seal Type.....	Single Internal
Stationary Seal Ring Material	Carbon (standard)
Also available in	Silicon Carbide
Single Rotating Seal Material	Chrome Oxide coated Stainless Steel
Also available in	Silicon Carbide
Double Rotating Seal Material (FP only).....	Ceramic
O-ring Material	Viton (standard)
Also available in	others available upon request

RECOMMENDED TORQUE VALUES

Impeller nut	40 ft.-lbs.	(for 250TC - 320TC/TSD motor frames)
Impeller nut	90 ft.-lb.	(for all models 1050, 1150 and 4000)
Shaft clamping bolt	15 ft.-lb.	(for 5/16" bolts)
Shaft clamping bolt	40 ft.-lb.	(for 3/8" bolts)
Shaft clamping bolt	85 ft.-lbs.	(for 1/2" bolts)
Motor bolts	50 ft.-lbs.	(for 250TC–280TC motor frames)
Motor bolts	70 ft.-lbs.	(for 320TSD motor frames)
Motor bolts	110 ft.-lbs.	(for 320–400 TC motor frames)
Seal retaining ring bolts	10 ft.-lbs.	(for all models except 4000)
Housing bolts	50 ft.-lbs.	(for all models except 4000)
Housing bolts	110 ft.-lbs.	(for 4000 model only)
Cover Nuts	110 ft.-lbs.	(for 4000 model only)

MOTOR INFORMATION

Uses standard NEMA TEFC C-face motors (except D-flange motors for 324 or 326TSD). Options include washdown, high efficiency, explosion proof, chemical duty and IEC. The TIR of the motor shaft should be 0.002" or less.

Voltage and Frequency	
3 phase, 60 Hz, 208-230/460 VAC	1750/3500 RPM
3 phase, 60 Hz, 575 VAC	1750/3500 RPM
3 phase, 50 Hz, 208-220/330-415 VAC	1450/2900 RPM

IMPELLER GAPS	TO HOUSING	TO COVER
700, 710, 720, 740, 1740, 352.....	0.5 mm (0.020") ..	0.5 mm (0.020")
353, 1050.....	1 mm (0.040")	0.5 mm (0.020")
354.....	1 mm (0.040")	1 mm (0.040")
345, 355.....	1.5 mm (0.060") ...	0.5 mm (0.020")
1150, 1160.....	1.5 mm (0.060") ...	2.0 mm (0.080")
4000.....	2.0 mm (0.080") ...	2.0 mm (0.080")

RECOMMENDED PREVENTIVE MAINTENANCE

RECOMMENDED SEAL MAINTENANCE

Visually inspect mechanical seal daily for leakage.
 Annually replace mechanical seal under normal duty.
 Replace mechanical seal as often as required under heavy duty.

ELASTOMER INSPECTION

Inspect all elastomers when performing pump maintenance. We recommend replacing elastomers (o-rings and gaskets) during seal replacements.

MOTOR LUBRICATION RECOMMENDATIONS

Use a high-grade ball and roller bearing grease. Recommendations for standard service conditions include *Shell Dolium R* or *Chevron SRI*. (See *Tables 1 - 3* for more information.)

Table 1: Motor Lubrication Intervals for Standard Conditions

<i>NEMA (IEC) Frame Size</i>	<i>Rated Speed - RPM</i>	
	<i>3500</i>	<i>1750</i>
Over 210 to 280 incl.(180)	3600 hrs.	9500 hrs.
Over 280 to 360 incl. (225)	2200 hrs.	7400 hrs.
Over 360 to 5800 incl. (300)	2200 hrs.	3500hrs

For severe service conditions, multiply interval hours by .5
 For extreme service conditions, multiply interval hours by .1

Table 2: Service Condition Definitions

<i>Service Max. Ambient Conditions</i>	<i>Atmospheric Temperature</i>	<i>Atmospheric Contamination</i>
Standard	104°F (40°C)	Clean, little corrosion
Severe	122°F (50°C)	Moderate dirt, corrosion
Extreme	>122°F (>50°C)	Severe, dirt abrasive dust, corrosion

Table 3: Volume of Grease to be Added

<i>Frame Size NEMA/IEC</i>	<i>Grease Volume</i>	
	<i>IN.³</i>	<i>TSP</i>
Over 210 to 280 incl. (180)	1.2	3.9
Over 280 to 360 incl. (225)	1.5	5.2
Over 360 to 449 incl. (280)	4.1	13.4

SEAL REPLACEMENT (735 & 736 SEAL SIZES)



Begin all pump maintenance by disconnecting the energy source to the pump. Observe all lock out/tag out procedures as outlined by ANSI Z244.1-1982 and OSHA 1910.147 to prevent accidental start-up and injury.

TOOLS FOR SEAL REPLACEMENT

- One 15/16" socket wrench
- One 1¼" socket wrench
- One 1¼" wrench
- One ¾" wrench
- One 7/16" wrench
- Pliers (channel locks)
- One soft-faced hammer
- One 3/8" diameter rod
- Optional: One pair impeller pullers (tack pullers)

PUMP HEAD DISASSEMBLY

Note: the reference numbers listed in the text (#) refer to the assembly drawing on pages 20 & 21.



WARNING

Disconnect the suction and discharge pipe from the pump. Drain all fluid from the pump prior to disassembly.

- a) Loosen the cover nuts (26) with the soft-faced hammer and remove.
- b) Next remove the pump cover (24) and the cover gasket (21).
- c) Remove the seal water pipes (on pumps with a double mechanical seal only) by turning them counter-clockwise with the pliers.
- d) Loosen and remove the guard nuts (3). Next, remove shaft guards (4).
- e) Place the 3/8" diameter rod in the pump shaft hole. Allow the rod to rest against the pump flange support (2) to prevent the shaft from rotating while loosening the impeller nut (23) with the 15/16" socket wrench (*Figure 7*). Remove the impeller nut and impeller nut gasket.
- f) Remove the impeller (22) from the pump shaft (7) by grasping an impeller blade in each hand and pulling the impeller toward

Figure 7

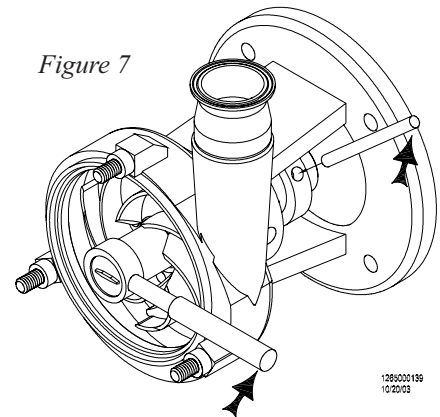
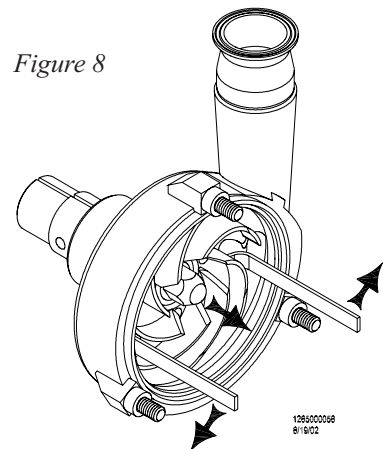

Figure 8



you. If the impeller is difficult to pull off the shaft, wedge the impeller pullers between the pump housing (10) and the back of the impeller and pry off the impeller (*Figure 8*).

- g) Compress the seal spring (34) by pushing on the front seal driver (36) and lift out the impeller key (8) (*Figure 9*). (You may find it easier to rotate the keyway to the bottom of the shaft, compress the seal spring and let the key drop out.)
- i) Next remove the front seal driver (36) and seal spring (34) by pulling them off the pump shaft and discard them.
- j) Remove the rotating seal (33), seal washer (13) and o-ring (14) by gently placing the flat ends of two impeller pullers on either side of the rotating seal and carefully pull (wiggling the seal ring side-to-side should aid removal) until the rotating seal face comes off the shaft (*Figure 10*). Discard seal components after you remove them.
- k) Loosen and remove the four housing bolts that pass through the flange support and thread into the back of the pump housing with the 3/4" wrench.
- l) Slide the pump housing off the end of the pump shaft.
- n) Place the pump housing face down on the housing bolts (38).
- m) Loosen the retaining ring bolts (16) with the 7/16" wrench and remove them from the hub of the pump housing. Remove the seal retaining ring (17).
- o) Remove and discard the stationary seal by placing your fingers in the center of the seal and pulling up (*Figure 11*). If the stationary seal has been in the pump for an extended period, it may be necessary to softly tap it out from the opposite end using a soft-faced hammer.
- p) Remove and discard the flat gasket (*Figure 11*) and clean the seal cavity if necessary.

Figure 9

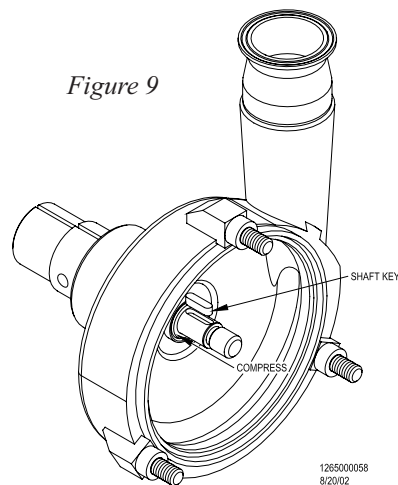

Figure 10

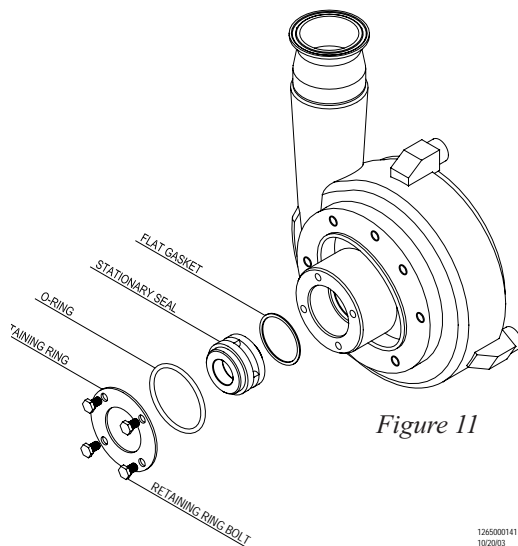
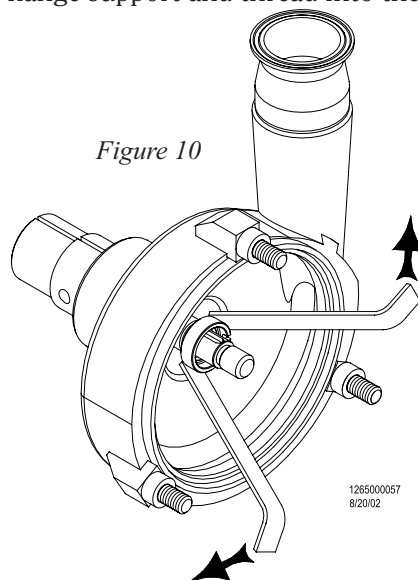
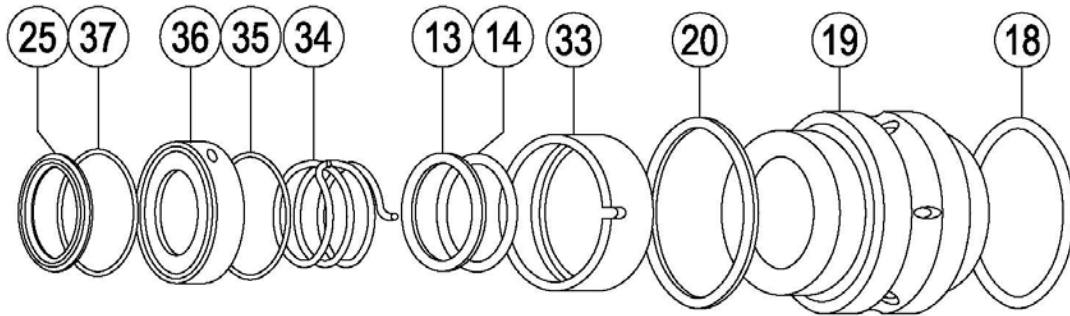

Figure 12: Single Seal Assembly (FPX Seal Size 735 & 736)



DESCRIPTION

- | | |
|-------------------------------|---------------------------|
| ②⑤ IMPELLER NUT GASKET | ①④ ROTATING SEAL O-RING |
| ③⑦ OUTSIDE SEAL DRIVER O-RING | ③③ ROTATING SEAL |
| ③⑥ FRONT SEAL DRIVER | ②① FLAT GASKET |
| ③⑤ INSIDE SEAL DRIVER O-RING | ①⑨ STATIONARY SEAL |
| ③④ SEAL SPRING | ①⑧ STATIONARY SEAL O-RING |
| ①③ ROTATING SEAL WASHER | |

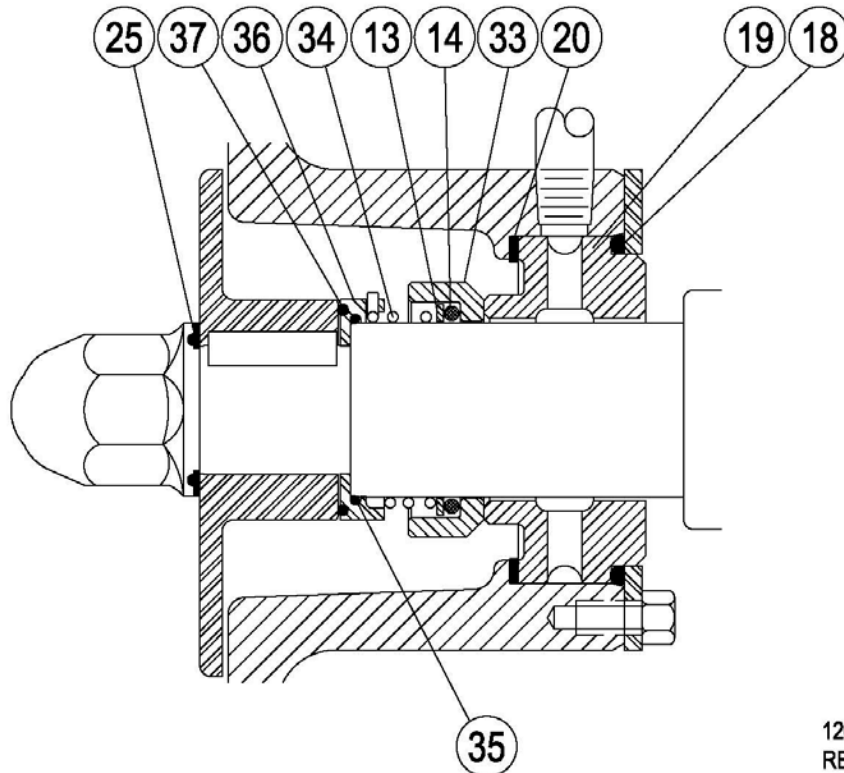
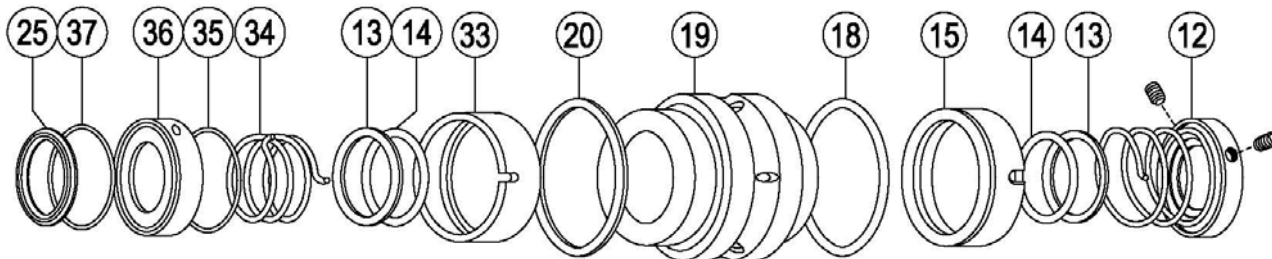
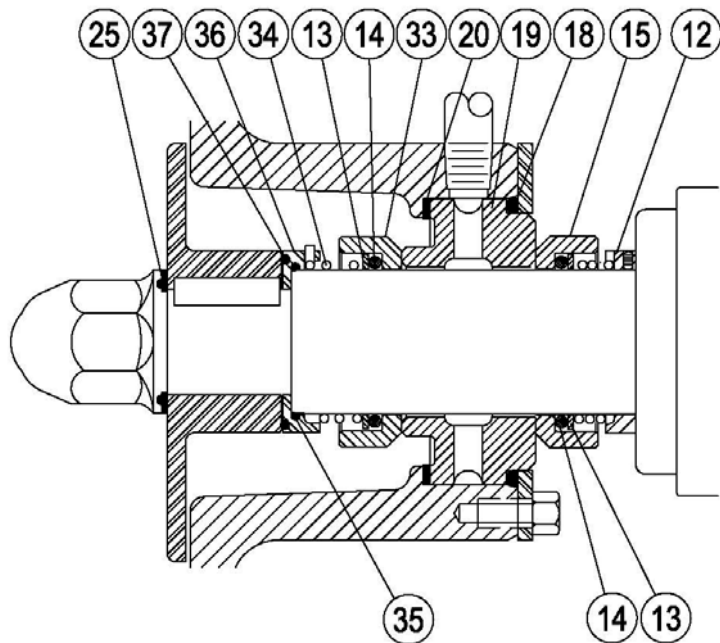

Figure 13: Double Seal Assembly (FP Seal Size 735 & 736)



DESCRIPTION

- | | |
|-------------------------------|------------------------------|
| ②⑤ IMPELLER NUT GASKET | ③③ FRONT ROTATING SEAL |
| ③⑦ OUTSIDE SEAL DRIVER O-RING | ②① FLAT GASKET |
| ③⑥ FRONT SEAL DRIVER | ①⑨ STATIONARY SEAL |
| ③⑤ INSIDE SEAL DRIVER O-RING | ①⑧ STATIONARY SEAL O-RING |
| ③④ FRONT SEAL SPRING | ①⑤ REAR ROTATING SEAL |
| ①③ ROTATING SEAL WASHER | ①② REAR SEAL DRIVER & SPRING |
| ①④ ROTATING SEAL O-RING | |



For *Double Mechanical Seals Only* - remove and discard the rear rotating seal (15), seal washer (13), and the seal o-ring (14) off the pump shaft. Use an Allen wrench to remove rear seal driver and spring (12) off the shaft and discard.

PUMP HEAD ASSEMBLY – (SEE SEAL ASSEMBLY DRAWING - FIGURES 12 & 13)

NOTE: when installing the new seal components make sure that you use all of the components supplied with the replacement seal kit. Using some of the old components may reduce seal life.

For double mechanical seals only (FP Series only), first install the rear seal components. Note: this includes the seal washer (13), the seal o-ring (14), the rear rotating seal (15) and the rear seal driver and spring (12).

You are now ready to install the new mechanical seal into the pump.

- a) To install the stationary seal into the pump housing, place the pump housing on a clean surface with the hub side up. Inspect the hub area to ensure that it is clean.
- b) Place the flat gasket (20) into the hub of the pump housing. Make sure that it is all the way to the bottom and seated evenly.
- c) Install the stationary seal into the housing hub, with the smaller face entering the hub first.
- d) Install the stationary seal o-ring (18) (do *not* lubricate this o-ring) onto the back of the stationary seal (19). Improper fit may cause leakage or seal damage.
- e) Place the retaining ring (17) on the housing hub, align the holes in the retaining ring with the holes in the hub.
- f) Thread the four (or six) retaining bolts (16) through the holes in the retaining ring and into the housing hub. Alternately tighten the bolts so the retaining ring secures evenly. Uneven tightening could result in seal damage. Check for proper torque on page 5.
- g) Carefully slide the pump housing (10) over the pump shaft (7) and back against the flange support (2). *Note: the stationary seal may be damaged if it makes hard contact with the pump shaft.*
- h) Install the housing bolts (29) and washers (30). Tighten to the proper torque listed on page 4. Install the seal water pipe (if supplied), by threading it into the housing and tighten with a pair of pliers. Align the discharge piping with the discharge outlet.
- i) You are now ready to install the rotating seal assembly (*Figure 14*). First lightly lubricate the new seal o-ring (14) with a food grade lubricant (if the o-ring material is EPDM, then only water should be used for lubrication). Place the seal o-ring inside the rotating seal (33).
- j) Now place the seal washer (13) into the rotating seal.
- k) Next install the seal spring (24) into the rotating seal making sure that the tab of the spring is in the slot on the rotating seal. (*Note: for frame sizes 254 and up, the larger end of the seal spring goes into the rotating seal *Figure 14*.*)

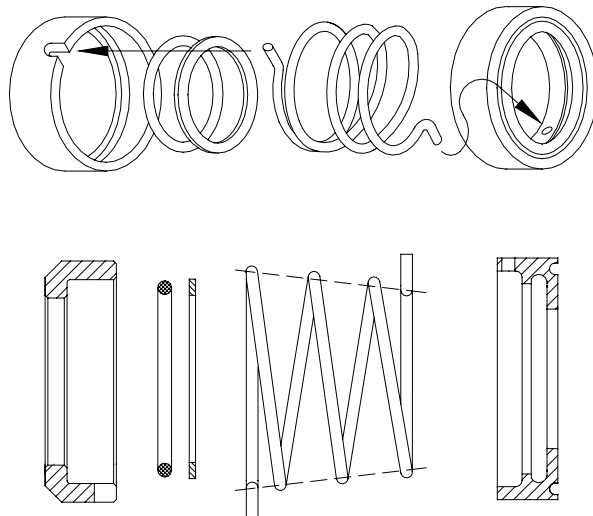

1265000352 REV-

Figure 14

- l) Finally, install the tab on the other end of the seal spring into the hole on the front seal driver (36). The rotating seal assembly is now ready to be installed onto the pump shaft.
- m) Rotate the pump shaft (7) so the keyway is on top. Now slide the rotating seal assembly which includes: the rotating seal (33), seal o-ring (14), seal washer (13), seal spring (34) and the front seal driver (36) onto the pump shaft.
- n) Lubricate the outside seal driver o-ring (35) with a food grade lubricant, if it is not EPDM, and install it in the groove on the front of the seal spring and driver assembly.
- o) Now compress the spring assembly with two fingers and install the impeller key (8) into the keyway on the pump shaft (*Figure 15*).
- p) Slide the impeller (22) onto the pump shaft (7). The slot in the impeller hub will slide over the impeller key (8).

Figure 15

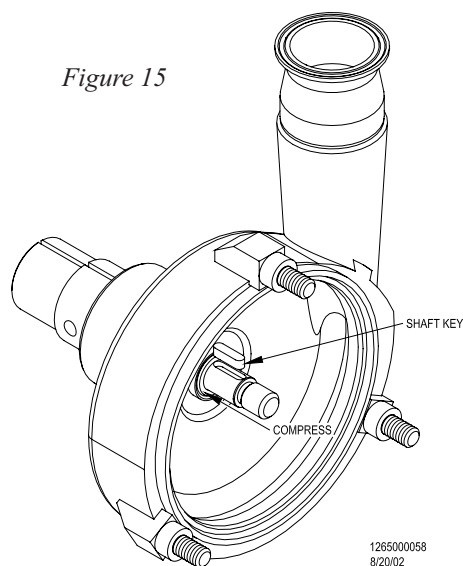

- q) Lubricate the new impeller nut gasket with a food grade lubricant (if it is not EPDM) and place it onto the impeller nut (23).
- r) Thread the impeller nut with the gasket in place onto the pump shaft (7). Place the 5/16" diameter rod in the pump shaft hole. Allow the rod to rest against the pump flange support (2) to keep the shaft from rotating while tightening the impeller nut (23) with the 15/16" socket wrench (*Figure 16*). Tighten to the proper torque (see page 5). Remove the rod.
- s) Now install the new cover gasket (25) onto the pump cover (24). When placing the cover gasket into the pump cover, gently stretch the gasket into position. Do not roll the gasket into position. With the cover gasket in position, place the pump cover onto the front of the pump. (*Note:* the pump serial number is stamped into the 'top' of the pump cover.)

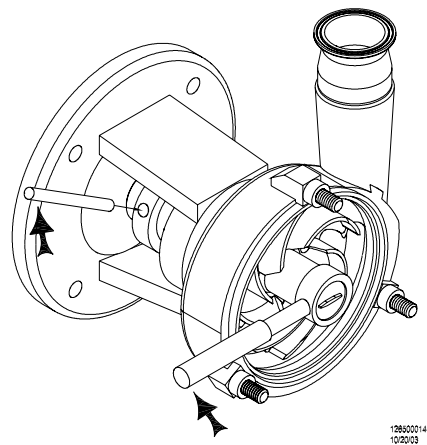

- t) Thread the cover nuts (26) onto the housing studs (38). Make sure the cover o-ring is properly seated in the cover to ensure that it will not get pinched when tightening the cover nuts. Tighten the cover nuts by tapping on them with the soft-faced mallet.

Figure 17

- u) Now rotate the pump shaft (7) to make sure that the impeller (22) moves freely. If it does not, recheck your assembly to make sure that gaskets are not pinched and everything is seated properly. Listen to the pump as you turn the shaft. A small amount of noise from the seals is normal, but if there is metal-to-metal contact, the sound will be noticeable. If there is metal-to-metal contact, check the impeller gap. Regap the impeller if necessary. See pages 18-19 for directions. Replace the shaft guard (4) and secure with the guard screws (3).

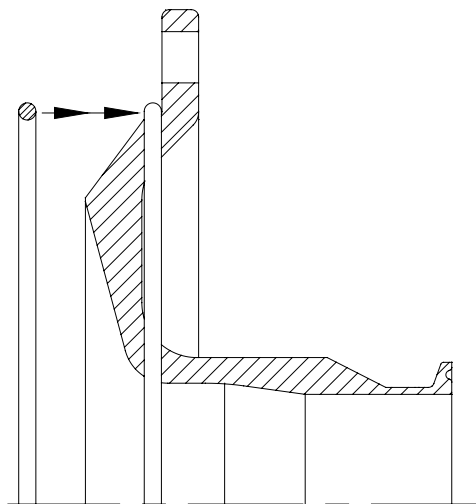

Reconnect the suction and discharge piping.

WARNING: Mechanical seals must never run dry, even momentarily. Seal damage may result.

SEAL REPLACEMENT - FP 4000 MODEL (102 SEAL SIZE)



Begin all pump maintenance by disconnecting the energy source to the pump. Observe all lock out/tag out procedures as outlined by ANSI Z244.1-1982 and OSHA 1910.147 to prevent accidental start-up and injury.

TOOLS FOR SEAL REPLACEMENT

- socket wrench
- 15/16" socket
- 1 1/4" socket
- Ratchet
- Pliers (channel locks)
- One soft-faced hammer
- One 5/16" diameter rod
- Optional: One pair impeller pullers (tack pullers)

PUMP HEAD DISASSEMBLY

Note: the reference numbers listed in the text (#) refer to the pump assembly drawing on pages 22 & 23.



WARNING

Disconnect the suction and discharge pipe from the pump. Drain all fluid from the pump

prior to disassembly.

- a) Remove the cover nuts (25) with the 15/16" socket.
- b) Remove the pump cover (24) and the cover gasket (21).
- c) Remove the guard nuts (3) and remove shaft guards (4).
- d) Place a 5/16" diameter rod in a hole in the shaft (7). Hold the rod to keep the shaft from rotating while loosening the impeller nut (23) with the 1 1/4" socket wrench (*Figure 18*).
- e) Remove the impeller nut and impeller nut gasket (25).
- f) Remove the impeller (22) from the pump shaft (7) by grasping an impeller blade in each hand and pulling the impeller toward you.
- g) After the impeller is removed, place it on a clean flat surface with the blades facing down. The rotating seal is located in hub of the impeller. Remove and discard the rotating seal (33), o-rings (25 & 41) and wave spring (34).
- h) Next remove and discard the stationary seal (19) by pushing on back of seal and sliding it forward out of the housing.

For *Double Mechanical Seals Only* - remove the rear rotating seal (15) and wave spring off the pump shaft and discard. The rear rotating seal can also be pulled forward from the back of the pump housing.

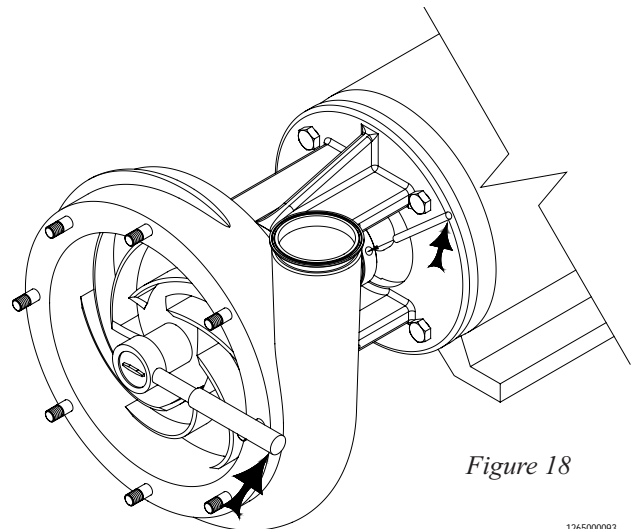

Figure 18

1265000093
1/30/03

PUMP HEAD ASSEMBLY (FP 4000 MODEL)– (SEE SEAL ASSEMBLY DRAWING - FIGURES 22 & 23)

NOTE: when installing the new seal components make sure that you use all of the components supplied with the replacement seal kit. Using some of the old components may reduce seal life. Lubricate all o-rings with a food grade lubricant, unless otherwise specified in the manual.

For *Double Mechanical Seals Only*

1) Generously lubricate the inner o-ring (unless the o-ring material is EPDM, then only water should be used for lubrication) and install on the rear rotating seal.

2) Install the rear wave spring into the back of the rear rotating seal.

3) Slide the rear rotating seal on the pump shaft. Note: Align the grooves in the rotating seal with the pins in the pump shaft. If the seal is installed properly, it will not rotate.

4) Generously lubricate both stationary seal o-rings (unless the o-ring material is EPDM, then only water should be used for lubrication) and install. Improper fit may cause leakage or seal damage.

5) Slide the stationary seal onto the pump shaft. Align the flat ends of the stationary seal with the flat edges of the housing (*Figure 19*).

6) Lubricate both rotating seal o-rings with a food grade lubricant (unless the o-ring material is EPDM, then only water should be used for lubrication). Install the seal o-rings onto the rotating seal (33).

7) With the impeller, blades on a clean surface, place the wave spring into the hub of the impeller.

8) Next install the rotating seal into the hub of the impeller (*Figure 20*). Note: Align the pins in the hub of the impeller with the grooves of the rotating seal. If the seal is installed properly, it will not rotate.

9) Now you are ready to install the impeller. First align the shaft key slot on the impeller with the shaft key on the pump shaft. Now carefully install the impeller, making sure that the rotating seal doesn't make contact with the pumps shaft. If contact does occur, the rotating seal may be damaged.

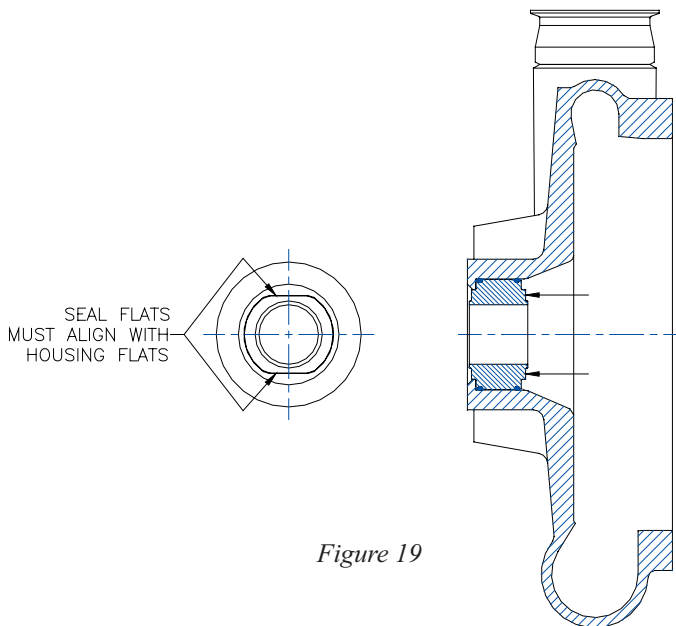

126500013
4/8/02

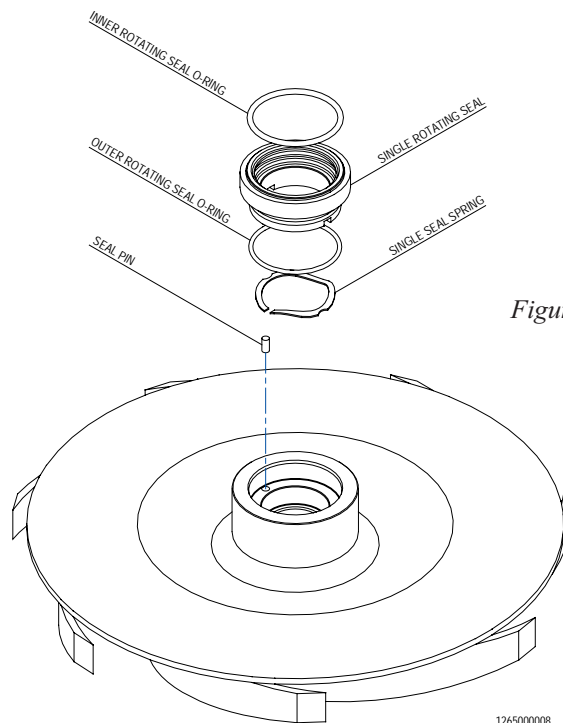
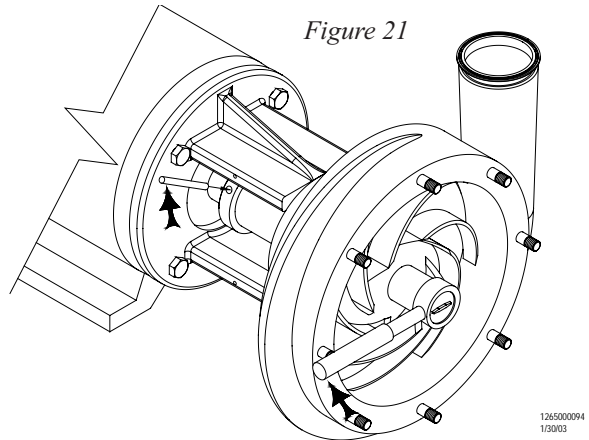

Figure 20

126500008
4/1/02

- 10) Lubricate the new impeller nut o-ring (25) with a food grade lubricant (if it is not EPDM) and place it onto the impeller nut (23).
- 11) Thread the impeller nut with the o-ring in place onto the pump shaft (7). Place a 5/16" diameter rod in a hole in the shaft (7). Hold the rod to keep the shaft from rotating while tightening the impeller nut with the 1 3/4" socket wrench (*Figure 21*). Check for the proper torque on page 4.
- 12) Now install the new cover o-ring (21) onto the pump cover (24) and install them onto the front of the pump. (*Note: the pump serial number is embossed into the 'top' of the pump cover.*) When placing the cover o-ring into the pump cover, gently stretch the o-ring into position. Do not roll the gasket into position.
- 13) Thread the cover nuts (26) onto the housing studs (238). Make sure the cover o-ring is properly seated in the cover to ensure that it will not get pinched when tightening the cover nuts. Tighten the cover nuts with a 15/16" socket (see page 4 for the proper torque).
- 14) Now rotate the pump shaft (7) to make sure that the impeller (22) moves freely. If it does not, recheck your assembly to make sure that gaskets are not pinched and everything is seated properly. Listen to the pump as you turn the shaft. A small amount of noise from the seals is normal, but if there is metal-to-metal contact, the sound will be noticeable. If there is metal-to-metal contact, check the impeller gap. Regap the impeller if necessary. See page 18 for directions. Replace the shaft guards (4) and secure with the guard nuts (3).



Reconnect the suction and discharge piping.

WARNING: Mechanical seals must never run dry, even momentarily. Seal damage will result.

Figure 22: Single Seal Assembly (FP Seal Size 102)

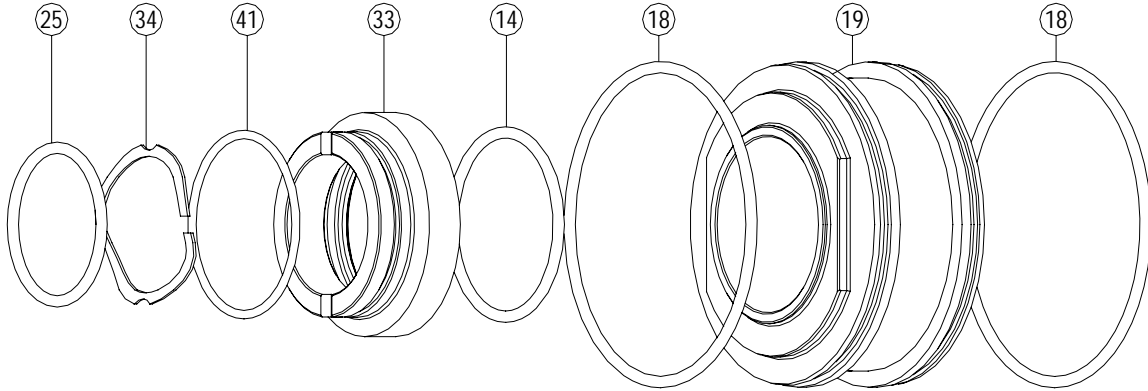

DESCRIPTION

- | | |
|-------------------------------|-------------------------------|
| ②⑤ IMPELLER NUT O-RING | ①④ INNER ROTATING SEAL O-RING |
| ③④ SINGLE SEAL SPRING | ①⑧ STATIONARY SEAL O-RING |
| ④① OUTER ROTATING SEAL O-RING | ①⑨ STATIONARY SEAL |
| ③③ SINGLE ROTATING SEAL | |

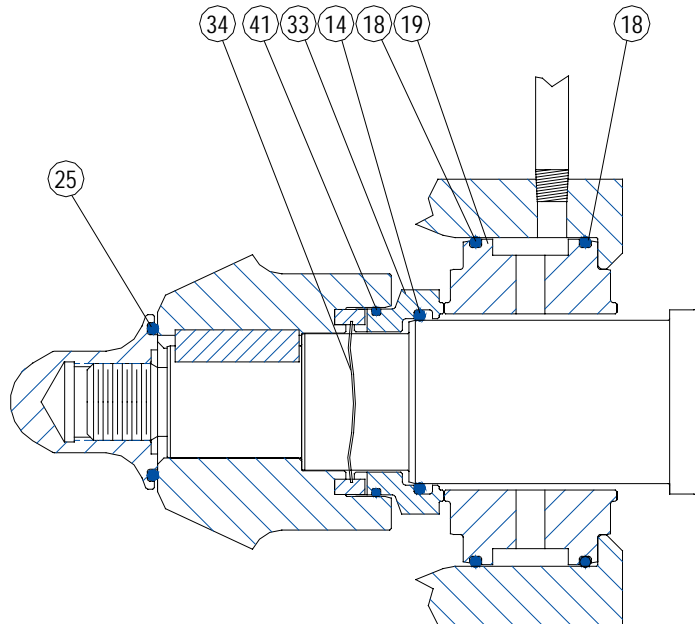
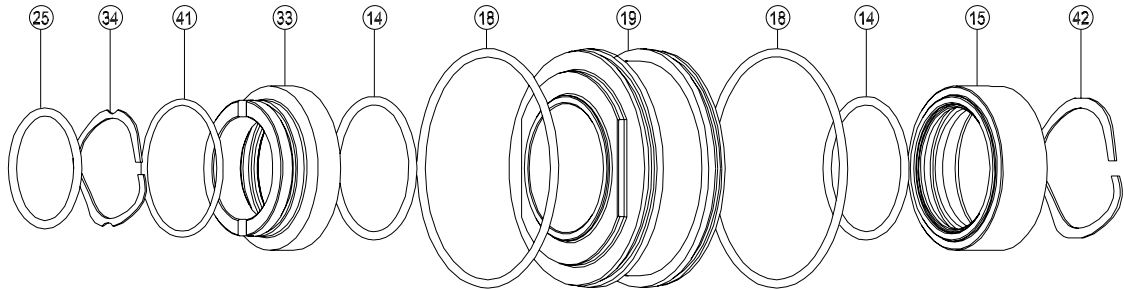
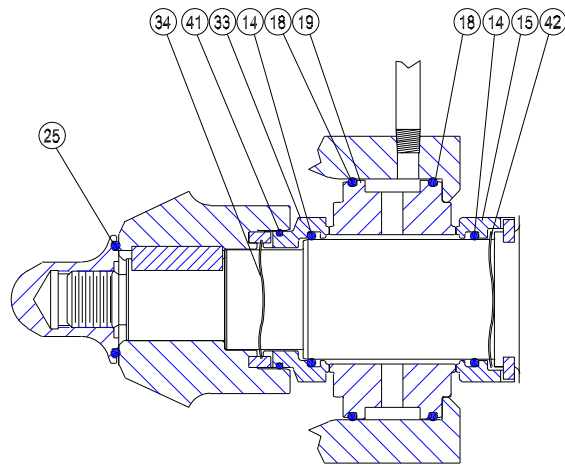

Figure 23: Double Seal Assembly (FP Seal Size 102)



DESCRIPTION

- | | |
|-------------------------------|---------------------------|
| ②⑤ IMPELLER NUT O-RING | ①⑧ STATIONARY SEAL O-RING |
| ③④ SINGLE SEAL SPRING | ①⑨ STATIONARY SEAL |
| ④① OUTER ROTATING SEAL O-RING | ①⑤ DOUBLE ROTATING SEAL |
| ③③ SINGLE ROTATING SEAL | ④② DOUBLE SEAL SPRING |
| ①④ INNER ROTATING SEAL O-RING | |



1285000007
3/26/02

PUMP SHAFT AND/OR MOTOR REPLACEMENT - MOTOR FRAME SIZE 254 TC - 405 TC (please contact Fristam for 440TC instructions)



Begin all pump maintenance by disconnecting the energy source to the pump. Observe all lock out/tag out procedures as outlined by ANSIZ244.1-1982 and OSHA 1910.147 to prevent accidental start-up and injury.

TOOLS FOR PUMP SHAFT AND/OR MOTOR REPLACEMENT

3/4" wrench	(for 254–286TC motor frames)
Two 1-1/8" wrenches	(for 324–326TSD motor frames)
15/16" wrench	(for 324 - 445 TC motor frames)
9/16" wrench	
Soft-faced hammer	
One set of feeler gauges	
3/16" Allen wrench socket	(for 56C – 180TC shaft collars)
1/4" Allen wrench socket	(for 210TC – 250TC shaft collars)
5/16" Allen wrench socket	(for 280TC – 360TSC shaft collars)

PUMP DISASSEMBLY

- Disassemble the pump head as described on pages 5-6.
- Loosen the shaft collar screw (36) on the shaft collar (37) with the 3/16" or 1/4" or 5/16" Allen wrench (depending on the motor frame size).
- Pull the pump shaft off the motor shaft. If necessary, rotate the pump shaft and tap with the soft-faced mallet to loosen the pump shaft from the motor shaft.

If the pump shaft does not pull off the motor shaft, the pump housing (10) and impeller (22) can be reinstalled to aid in removal. To do this, first ensure that the stationary seal (19) is not in the pump housing. Next install the pump housing onto the flange support (2). Install the impeller onto the pump shaft and place a clean cloth or brass shim between the impeller and pump housing to prevent the impeller from scratching the pump housing during the shaft removal process. Thread the impeller nut (23) and impeller nut gasket (25) onto the shaft and tighten by hand. Now pull on the pump housing to loosen the pump shaft from the motor shaft. Tapping on the back of the pump housing with the soft-faced mallet may be required.

The use of the shaft puller, available from Fristam, is another method to remove the pump shaft.

MOTOR REPLACEMENT ONLY

Loosen the motor bolts (28) with the 3/4" wrench and remove the bolts and lock washers (27) that pass through the flange support (2) and thread into the C-face of the motor. For 324 and 326 TSD frame motors, use two 1-1/8" wrenches to remove the bolts and lock washers that pass through the flange support and thread into the D-face motor. Remove the flange support (2) from the motor (1).

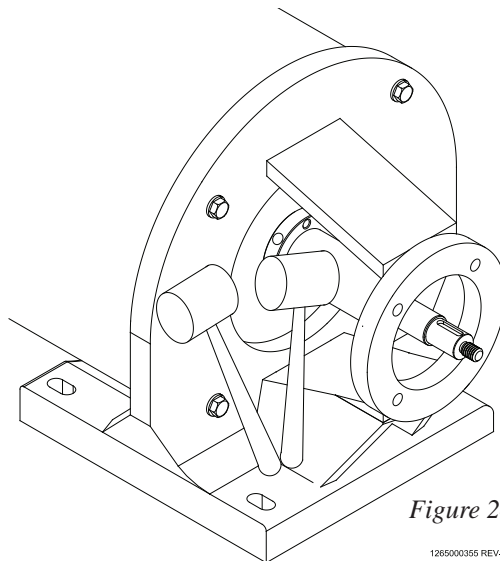

Figure 24

1265000365 REV.

ASSEMBLING THE MOTOR TO THE FLANGE SUPPORT

If you have replaced the motor, clean off the motor face of the flange support (2). Place the flange support on the new motor, replace the motor bolts (28) and lock washers (27). Tighten the motor bolts to the appropriate torque (see page 5).

For motor frame sizes up to and including 286 TC: The four hex bolts (28) with lock washers (27) are placed through the holes in the flange support then threaded into the tapped holes on the C-face of the motor.

For 324 and 326 TSD motors:
The four hex bolts (28) are placed through the holes on the flange support and motor then fasten with a lock washer (27) and nut (38) .

Tighten the motor bolts to the proper torque listed on page 4.

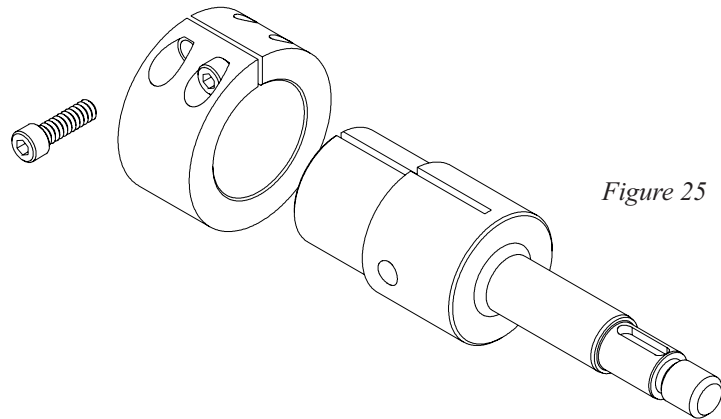

128500143
10/21/03

ASSEMBLING THE PUMP SHAFT TO THE MOTOR SHAFT

Note: when replacing the shaft, replace the shaft collar at the same time.

- a) Slide the new shaft collar (6) onto the pump shaft, do not tighten the shaft collar screw at this time.
- b) Slide the pump shaft assembly onto the motor shaft with the hole in the pump shaft aligned with the key in the motor shaft.
- c) Tighten the shaft collar screw (5).

SETTING THE IMPELLER GAP

If you have removed the pump shaft (7) from the motor shaft for any reason (such as replacing the shaft or motor), you must re-set the gap.

The gap is measured between the impeller (22) and pump housing (10) using feeler gauges. (NOTE: Due to polishing and balancing the impeller, the gap behind each impeller blade may vary. The gap should be checked behind each blade and the smallest value should be used as your gap setting.) The correct gap dimensions are listed on page 5.

- a) To set the gap, place the original housing shim, if supplied, with the pump and the pump housing (less the stationary seal) on the flange support (2).
- b) Bolt the housing in place.
- c) Slide the front seal driver (or seal drive spacer) onto the pump shaft (7).
- d) Install the impeller key (8), impeller (22) and impeller nut (23). Tighten the impeller nut while holding onto the impeller blades.
- e) Once the impeller is secure, place the appropriate feeler gauge between the impeller blades and the housing (shim stock may also be used). Lightly tap on the impeller nut with a soft-faced hammer to drive the shaft back until the impeller is up against the feeler gauge. This sets the proper gap.

g) *Align the slot of the shaft collar (6) directly over one of the slots on the shaft (Figure 24).*

h) Tighten the shaft collar screw (5) in the shaft collar (6) to the proper torque, see page 4 (*Figure 25*).

i) Remove the feeler gauge.

Check the gap behind each blade of the impeller to see if the gap on each blade is correct, see the chart on the previous page for correct gap.

Now remove the impeller nut (23), impeller (22), impeller key (8), front seal driver (36) and pump housing (10). Now you are ready to assemble the pump head as described on pages 11-13.

If the gap does not fall within tolerance, call Fristam Pumps.

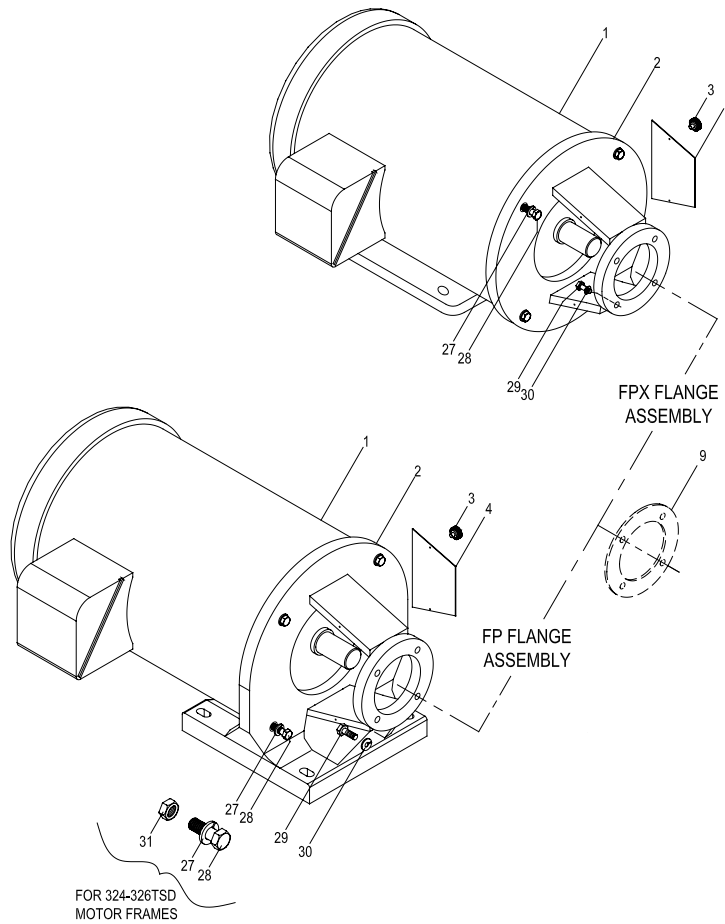

FP DOUBLE FLANGE (735 & 736 SEAL SIZES) EXPLODED VIEW

- | | |
|---------------------------------|---------------------------------|
| 1. Motor | 17. Retaining Ring |
| 2. Flange Support | 18. Stationary Seal O-ring |
| 3. Guard Nuts | 19. Stationary Seal |
| 4. Shaft Guards | 20. Stationary Seal Flat Gasket |
| 5. Shaft Collar Screw | 21. Cover Gasket |
| 6. Shaft Collar | 22. Impeller |
| 7. Shaft | 23. Impeller Nut |
| 8. Impeller key | 24. Pump Cover |
| 9. Shim (for some frame sizes) | 25. Impeller Nut Gasket |
| 10. Pump Housing | 26. Cover Nuts |
| 11. Set Screw | 27. Motor Lock Washer |
| 12. Rear Seal Driver and Spring | 28. Motor Bolts |
| 13. Seal Washer | 29. Housing Bolts |
| 14. Seal O-ring | 30. Housing Lock Washer |
| 15. Rear Rotating Seal | 31. Motor Nut |
| 16. Retaining Ring Bolts | 32. Water Piping (optional) |
| | 33. Front Rotating Seal |

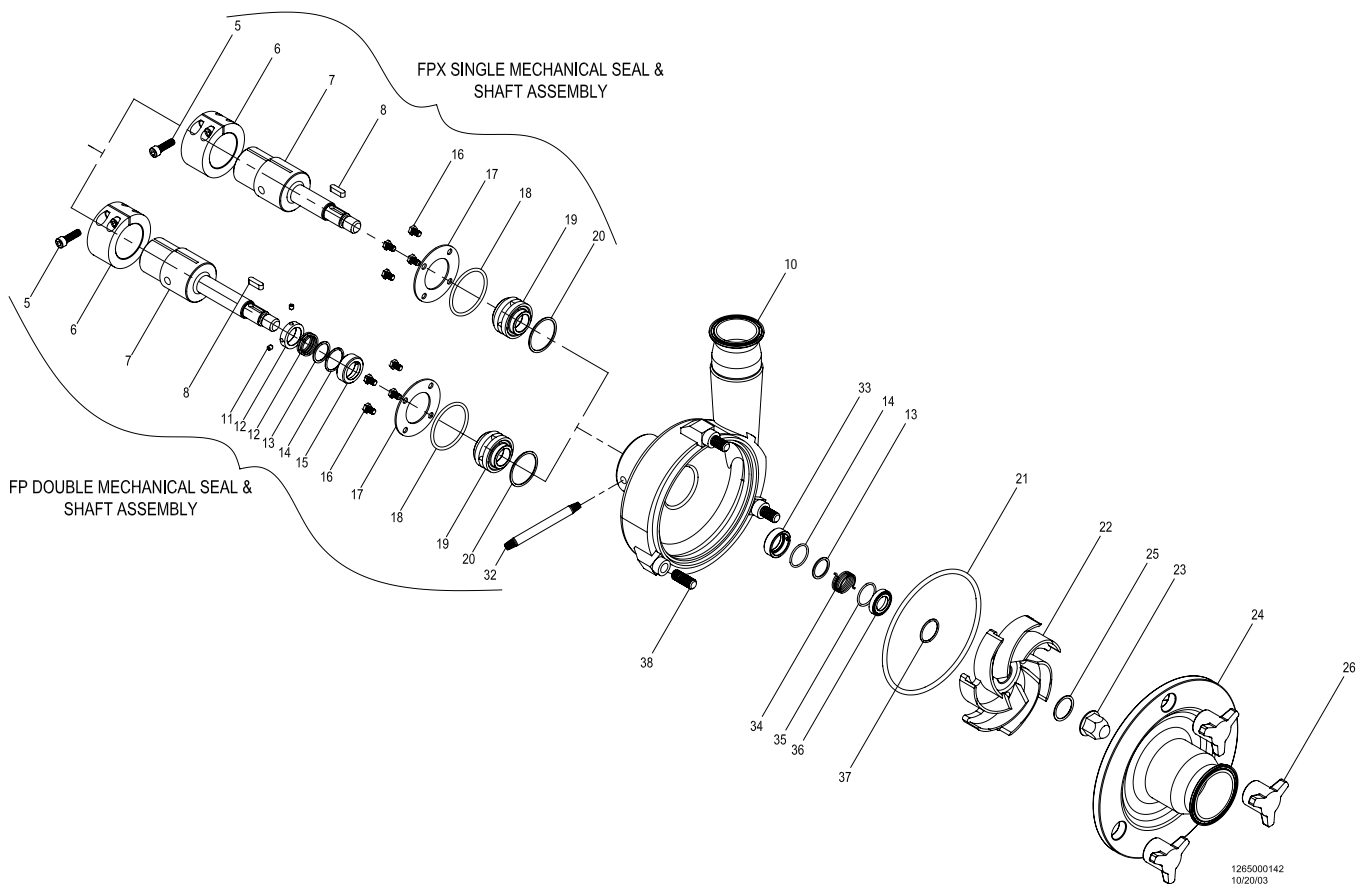

- 34. Seal Spring
- 35. Inside Seal Driver O-ring (factory installed)
- 36. Seal Driver
- 37. Gasket
- 38. Housing Stud

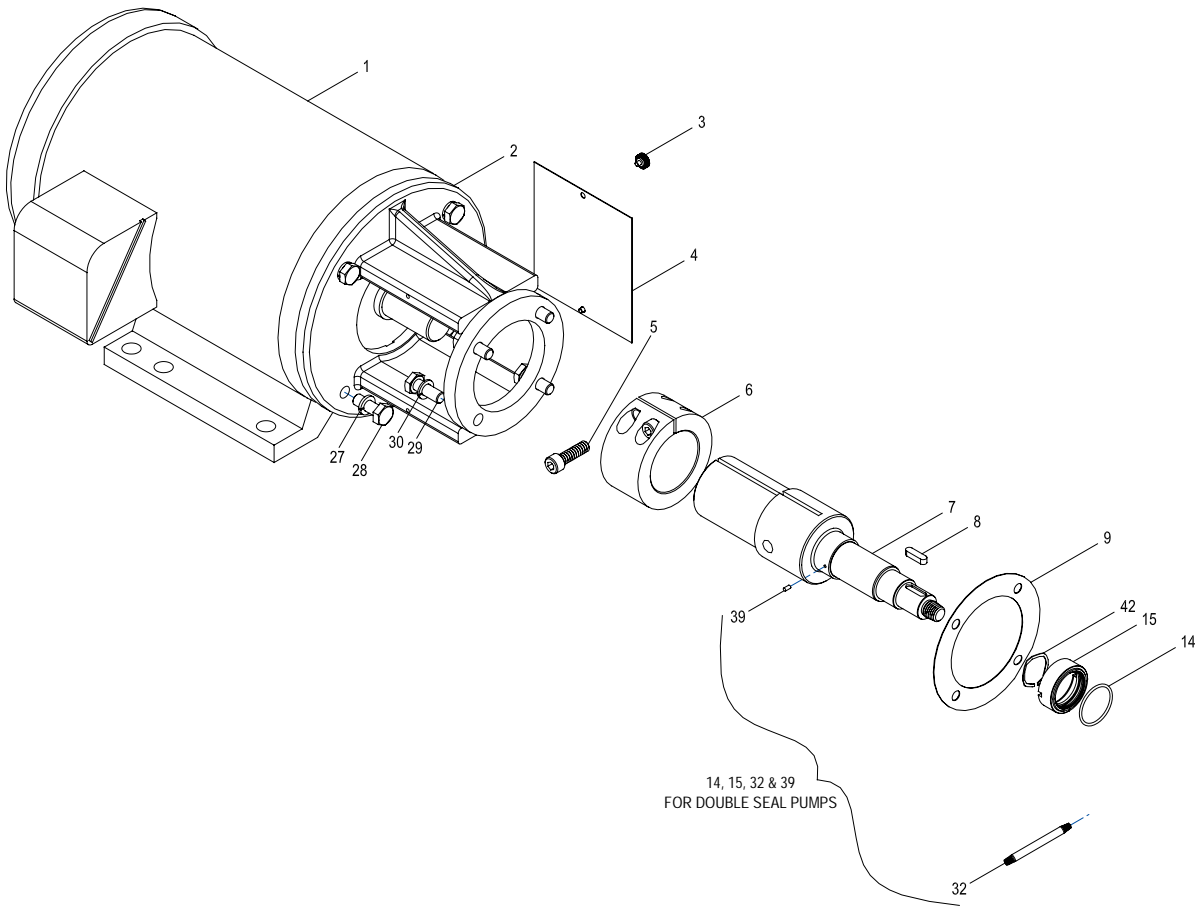

FP DOUBLE FLANGE (4000 SERIES - 102 SEAL SIZE) EXPLODED VIEW

- | | |
|--------------------------------|---|
| 1. Motor | 25. Impeller Nut Gasket |
| 2. Flange Support | 26. Cover Nuts |
| 3. Guard Nuts | 27. Motor Lock Washer |
| 4. Shaft Guards | 28. Motor Bolts |
| 5. Shaft Collar Screw | 29. Housing Bolts |
| 6. Shaft Collar | 30. Housing Lock Washer |
| 7. Shaft | 32. Water Piping (optional) |
| 8. Impeller key | 33. Front Rotating Seal |
| 9. Shim (for some frame sizes) | 34. Seal Spring |
| 10. Pump Housing | 35. Inside Seal Driver O-ring (factory installed) |
| 14. Seal O-ring | 36. Seal Driver |
| 15. Rear Rotating Seal | 37. Gasket |
| 18. Stationary Seal O-ring | 38. Housing Stud |
| 19. Stationary Seal | 39. Shaft Pin |
| 21. Cover Gasket | 40. Impeller Pin |
| 22. Impeller | 41. Outer Rotating Seal O-ring |
| 23. Impeller Nut | |
| 24. Pump Cover | |

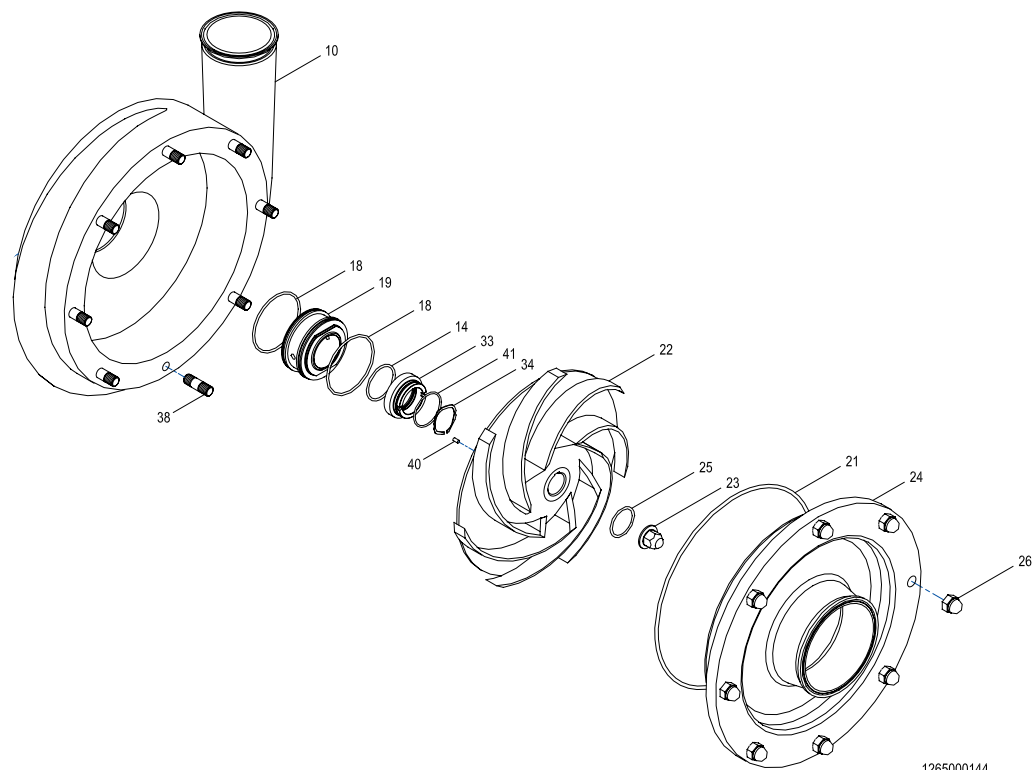

1265000144
10/21/03

INSTALLATION

UNPACKING

Check the contents and all wrapping when unpacking the pump. Inspect the pump carefully for any damage that may have occurred during shipping. Immediately report any damage to the carrier. Remove the shaft guard and rotate the pump shaft by hand to make sure the impeller rotates freely. Keep the protective caps over the pump inlet and outlet in place until you are ready to install the pump.

INSTALLING

Prior to actually installing the pump, ensure that:

- the pump will be readily accessible for maintenance, inspection and cleaning.
- adequate ventilation is provided for motor cooling.
- the drive and motor type is suitable for the environment where it is to be operated. Pumps intended for use in hazardous environments e.g., explosive, corrosive, etc., must use a motor and drive with the appropriate enclosure characteristics. Failure to use an appropriate motor type may result in serious damage and/or injury.

We ship our pumps fully assembled.

PIPING GUIDELINES

This section describes good piping practices to obtain maximum efficiency and service life from your pump.

Maximum performance and trouble-free operation require adherence to good piping practices.

- Ensuring proper piping support and alignment at both the suction inlet and discharge outlet can help prevent serious damage to the pump housing (**Figure 1**).
- Avoid abrupt transitions in the piping system (**Figure 2**).
- Avoid throttling valves in the suction piping.
- Keep suction lines as short and direct as possible.
- Ensure that the NPSH available in the system is greater than NPSH required by the pump.

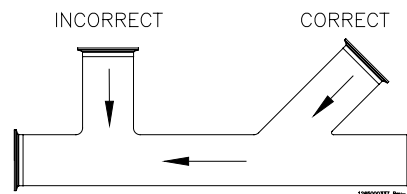

Figure 2

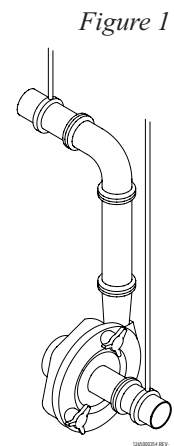
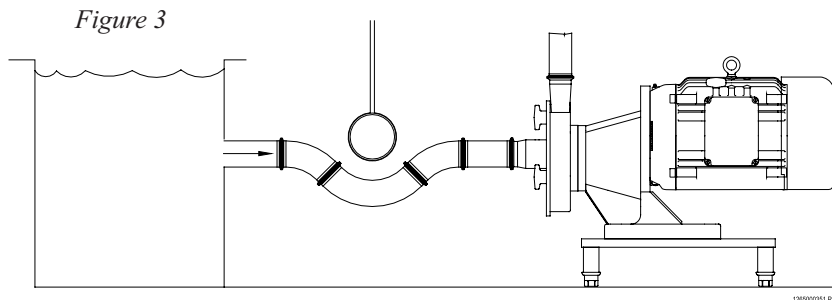
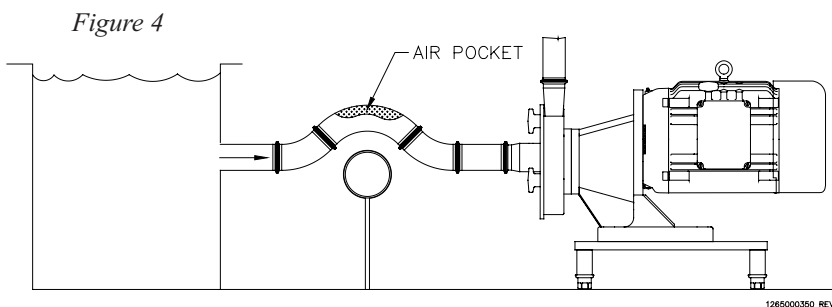

Figure 1

- Avoid sump areas where sediments may collect (**Figure 3**).



- Avoid the formation of air pockets in the piping (**Figure 4**).



- Avoid abrupt closure of shut-off valves, this may cause hydraulic shock which can cause severe damage to the pump and system.
- Avoid elbows in the suction line if possible. When necessary they should be located 5 pipe diameters away from the pump inlet, and have a bend radius greater than 2 pipe diameters (**Figure 5**).

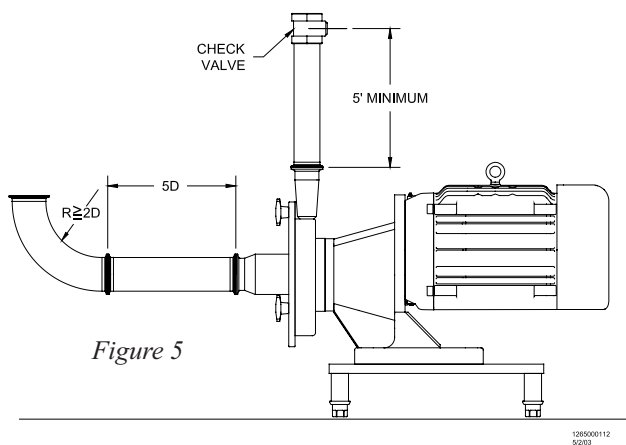

ELECTRICAL INSTALLATION

We use standard duty TEFC motors unless otherwise specified. Many motor options are available: wash-down, flameproof, explosion proof, hostile duty or chemical duty.

Have an electrician connect the motor using sound electrical practices. Provide adequate protection. Pumps fitted with mechanical seals must not run dry, not even momentarily. *Determine the direction of rotation by watching the motor fan, which must turn clockwise.*

The motor selected should meet the requirements of the specified operating conditions. A change in conditions (for example, higher viscosity, higher specific gravity, lower head losses) can overload the motor. When changing operating conditions or whenever there is any doubt, please contact Fristam Pumps Inc., for technical assistance.

PUMP OPERATIONS

START-UP INSTRUCTIONS

- Remove any foreign matter that may have entered the pump.
- Turn shaft by hand to make sure seals do not stick together otherwise, if motor is bumped in wrong direction it may unwind the seal spring.
- Do not use the pump to flush the system!

Check pump for proper rotation as indicated on the pump. *Proper motor direction is clockwise when looking at the fan end of the motor.* (NOTE: When checking the direction of rotation, the pump must be full of liquid.)

- Never run the pump dry, even momentarily. Seal damage may result.

SHUT-DOWN INSTRUCTIONS

- Shut off the power supply to the pump.
- Close the shut-off valves in the suction and discharge piping.
- Drain and clean the pump as required.
- Protect the pump against dust, heat, moisture and impact damage.

INSTALLATION OF WATER FLUSH FOR DOUBLE MECHANICAL SEAL

Set up the water flush for the double mechanical seal as shown (Figure 6). *Use only between 1-2 gallons per hour of water at a pressure of 5 PSI.* Excessive flow of water through the seal increases the pressure inside the seal. *Note: maximum pressure inside the seal is 5 PSI. Excessive flow/pressure through the seal flush will cause excessive wear and shorten seal life.*

Pipe the exit side of the water flush with 2-5 feet physical height of tubing. This ensures that some water is always in the center seal and the seal never runs dry.

It is possible to inject steam through the center seal (within the pressure requirements). We do not recommend using steam alone for the cooling/lubricating of the seal.

It is desirable to have the flush water on the outlet side visible. This allows an easy check to see that the flush water is on and also if the seal is functioning properly. In a malfunctioning seal the flush water will disappear, become discolored, or show an unusual increase in flow. If these conditions exist, check the seal and replace if necessary.

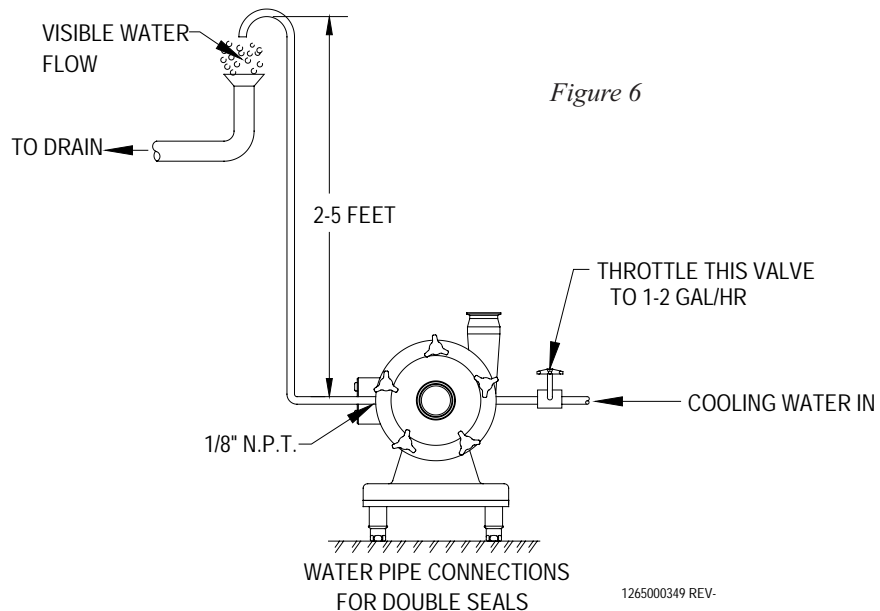

TROUBLESHOOTING

Fristam pumps are relatively maintenance free, however, in the event that a problem does arise, the troubleshooting chart below should help you with most of your pump related problems. If a motor problem arises please contact your local motor repair representative.

This troubleshooting chart has been prepared assuming that the pump installed is suitable for the application. Symptoms of cavitation can result when a pump is not properly applied. Examples of these symptoms are noisy operation, insufficient discharge, and vibration. If these conditions are present, check the system and re-evaluate the application. If you need assistance, contact Fristam Pumps at 1-800-841-5001 or 608-831-5001.

PROBLEM	POSSIBLE CAUSE OF TROUBLE
	(each number is defined in pages 20-22)
Pump does not deliver liquid	1, 2, 3, 4, 6, 14, 16, 17, 22, 23, 35, 41
Not enough capacity delivered	2, 3, 4, 5, 6, 7, 8, 9, 10, 14, 17, 20, 22, 23, 27, 28, 35, 41
Not enough pressure developed	5, 14, 16, 17, 20, 22, 27, 28, 35, 41
Pump loses prime after starting	2, 3, 5, 6, 7, 8
Pump requires too much power	15, 16, 17, 18, 19, 20, 23, 24, 25, 26, 30, 31, 34
Seal leaks	13, 25, 30, 31, 32
Seal has short life	11, 12, 13, 25, 27, 30, 31, 32, 33, 34, 35, 36
Pump vibrates or is noisy	2, 3, 4, 9, 10, 21, 23, 24, 25, 26, 27, 28, 33, 34, 35, 37, 38, 39, 40
Motor bearings have short life	25, 26, 27, 33, 34, 35, 37, 38, 39, 40
Pump overheats and seizes	1, 4, 21, 22, 26, 27, 33, 34, 35, 37, 38, 39, 40
Pump leaks from cover	29
SUCTION PROBLEMS	POSSIBLE SOLUTION
1. Pump not primed	1a) Adjust piping so that pump is flooded 1b) Install a foot valve to keep liquid in the pump
2. Pump or suction pipe not completely filled with liquid	2. Adjust piping so that suction pipe is filled with liquid
3. Suction lift too high	3. Raise the level of the liquid, lower the level of the pump
4. Insufficient difference between suction pressure and vapor pressure (cavitation)	4. Use larger pipe on the inlet side of the pump, raise the level of liquid above the pump centerline, lower the temperature of the liquid, eliminate fittings in suction line if possible, check inlet pipe for obstructions

- | | |
|--|--|
| 5. Too much air or gas in liquid | 5. Install air relief valve, turn pump head so discharge is at 45 degree angle |
| 6. Air pocket in suction line | 6. Adjust pipe to eliminate pocket |
| 7. Air leaks into suction line | 7. Find and fix air leak |
| 8. Air leaks into pump through seal | 8. Check seal for proper installation, replace seal if defective |
| 9. Foot valve too small | 9. Replace with larger foot valve |
| 10. Foot valve partially clogged | 10. Clear obstruction from foot valve |
| 11. Seal flush water not on | 11. Turn on water to seal flush |
| 12. Water seal pipe plugged | 12. Clear obstruction from seal water pipe |
| 13. Seal water flush pressure too high | 13. Adjust water flow to seal flush |

MECHANICAL PROBLEMS

- | | |
|---|--|
| 14. Speed too low | 14. Check electrical connections, consult motor manufacturer |
| 15. Speed too high | 15. Check electrical connections, consult motor manufacturer |
| 16. Direction of rotation wrong | 16. On a three-phase motor, switch any two of the three leads |
| 17. Total head of system higher than design head of pump | 17. Check for restrictions in the pipe, use larger diameter pipe, use larger diameter impeller, check application with Fristam Pumps. |
| 18. Total head of system lower than pump design head | 18. Install throttling valve in line, use smaller diameter pipe, use smaller diameter impeller, check with Fristam Pumps. |
| 19. Specific gravity of liquid greater than expected | 19. Use larger motor, check application with Fristam Pumps, Inc. |
| 20. Viscosity of liquid greater than expected | 20. Use larger motor, use larger diameter pipe, check application with Fristam Pumps. |
| 21. Operation at very low capacity | 21. Install throttling valve |
| 22. Parallel operation of pumps unsuitable for such operation | 22. Replace parallel pumps with a single larger pump |
| 23. Foreign matter in impeller | 23. Remove pump cover and clear foreign matter |
| 24. Foundations not rigid | 24. Provide firmer foundation for the pump |
| 25. Shaft bent | 25. Replace shaft |
| 26. Impeller rubbing on pump housing | 26. Re-establish gap of the impeller, replace impeller if defective, make sure impeller nut is tightened properly, check TIR of pump shaft |

- | | |
|---|--|
| 27. Motor bearings worn | 27. Replace motor bearings |
| 28. Impeller damage | 28. Replace impeller |
| 29. Cover gasket defective, permitting leakage | 29. Replace cover gasket |
| 30. Shaft or shaft sleeves worn or scored | 30. Replace pump shaft and/or sleeves |
| 31. Seal improperly installed | 31. Install seal correctly replace seal if defective |
| 32. Type of seal incorrect for operating conditions | 32. Replace seal with correct type of seal |
| 33. Pump shaft running off center because of worn bearing or misalignment | 33. Check motor bearings and replace if defective, indicate the pump shaft to .002” TIR |
| 34. Impeller out of balance causing vibration | 34. Balance the impeller |
| 35. Motor front bearing not locked | 35. Contact motor manufacturer for locking shim or to replace motor with a motor with locked front bearing |
| 36. Dirt or grit in sealing liquid, leading to scoring of shaft or seal surfaces | 36. Use clean source of water for seal flush |
| 37. Lack of lubrication in motor bearing | 37. Lubricate motor bearings |
| 38. Improper installation of antifriction bearings, (damage during assembly, incorrect assembly of stacked bearings, use of unmatched bearings as a pair, etc.) | 38. Re-install bearings correctly |
| 39. Dirt in bearings | 39. Clean bearings replace if defective |
| 40. Piping is obstructed | 40. Remove obstruction in pipe, check for closed valve |

NOTICE OF TERMS, WARRANTY PROVISIONS INCLUDING DISCLAIMERS, CLAIMS AND LIMITATION OF LIABILITY

Prices and all terms and conditions of sale are established in current price sheets and are subject to change without notice. All orders are subject to acceptance by Fristam Pumps USA Limited Partnership.

Each Fristam Pumps USA Limited Partnership, item is warranted to be free from manufacturing defects for a period of one (1) year from the date of shipment, providing it has been used as recommended and in accordance with recognized piping practice, and providing it has not been worn out due to severe service, such as encountered under extremely corrosive or abrasive conditions.

THIS WARRANTY IS EXPRESSLY IN LIEU OF ANY OTHER WARRANTIES EXPRESSED OR IMPLIED, INCLUDING BUT NOT LIMITED TO, ANY IMPLIED WARRANTY OF MERCHANTABILITY OR FITNESS FOR PARTICULAR PURPOSE. ALL OTHER WARRANTIES WHATSOEVER, EXPRESSED OR IMPLIED BY LAW OR OTHERWISE, ARE HEREBY EXCLUDED.

All claims must be in writing and must be mailed or delivered by purchaser within thirty (30) days after purchaser learns of the facts upon which such claim is based. Any claim not made in writing and within the time period specified above shall be deemed waived.

PURCHASER'S SOLE AND EXCLUSIVE REMEDY AND FRISTAM PUMPS USA LIMITED PARTNERSHIP MAXIMUM LIABILITY FOR CLAIMS ARISING HEREUNDER OR FOR NEGLIGENCE FOR ANY AND ALL LOSSES AND DAMAGES RESULTING FROM ANY CAUSE SHALL BE EITHER THE REPAIR OR REPLACEMENT OF DEFECTIVE ITEMS OR, AT FRISTAM PUMPS' OPTION, THE REFUND OF THE PURCHASE PRICE FOR SUCH ITEMS. IN NO EVENT, INCLUDING IN THE CASE OF A CLAIM FOR NEGLIGENCE, SHALL FRISTAM PUMPS BE LIABLE FOR INCIDENTAL OR CONSEQUENTIAL DAMAGES, INCLUDING LOSS OF PROFITS.

No person, including any representative employee or agent of Fristam Pumps USA Limited Partnership is authorized to assume on behalf of Fristam Pumps USA Limited Partnership any liability or responsibility in addition to or different from that described in this provision. Any and all representations, promises, warranties or statements that are in addition to or different from the terms of this provision are of no force or effect.

If any provision of this Notice is held to be invalid, such provision shall be severed and the remaining provisions shall continue to be in force.

