

Sanitary Centrifugal Pumps

FPR *Series*



Fristam Pumps...
Performance You've Come To Expect

omd ■ 800-648-3326
oliver m. dean, inc. ■ www.omdean.com

Fristam
PUMPS



FPR: The Preferred Centrifugal

Quality Begins with Fristam Pride

Fristam is an international manufacturer of sanitary centrifugal and positive displacement pumps, mixers and blenders that is respected for producing pumps with unmatched performance, reliability, and technical superiority.

Fristam pumps can be found in many of the world's top beverage, brewing, bio-pharmaceutical, and food processing companies.

Our dedication to continual improvement led to the development of the "easy maintenance" FPR Series centrifugal pump. The durable FPR is built with traditional Fristam quality and manufactured of 316L stainless steel.

Each part is carefully checked from raw material through final assembly. The result of this effort is a pump worthy of the valuable product your company produces.

Fristam pumps' solid design ensures operational reliability, low noise, and continued performance during sudden changes in pressure, even at very high discharge pressures.

Engineered for Performance

- Tight tolerances
- High efficiency
- Quiet operation
- Gentle product handling
- Reduced power consumption
- Isolated seal spring to meet stringent sanitary standards
- Heavy-duty solid cast and machined construction
- Fully balanced internal seal
- All 316L Stainless Steel wetted parts
- Low NPSH required

Made in the USA

Unlike many competitors, Fristam Pumps designs, machines, and assembles its pumps right here in the United States. This helps Fristam retain its unmatched quality, making it the pump company that is most responsive to its customers' needs.





Easy Maintenance

- Front pull-out seal design
- Fewer seal components
- No special tools required

Built with a front pull-out seal, FPR pumps are quickly serviced and do not need to be pulled out of line for seal changes. Processors save maintenance time and effort. Additionally, no special tools are required for service.



The Fristam front pull-out seal contributes to Fristam's unmatched seal life. The FPR features a cleaner design employing Fristam's experience in high pressure applications. Its fully balanced internal seal performs at all the designed pressures based on performance curves.

Less Maintenance Inventory

- Two seal sizes fit the entire line (except model 4001)
- Every shaft fits both a single and double seal
- Quick pump and part delivery

Within each pump model, seal size remains the same regardless of motor size. It is not necessary to stock different seals for different motors on the same model.

FPR pump shafts are designed to fit both the single and double mechanical seal arrangements. Processors can switch from single to double seal configurations without changing their shaft. This reduces the number of shafts needed to stock for spare parts.

Additionally, our responsive factory provides for quick pump and parts delivery.

Easy Cleaning

Fully CIP'able, the FPR meets the most stringent sanitary standards. An optional stainless steel flange provides extra corrosion resistance.

- Product viscosity up to 1,200 cps
- Process temperatures up to 400°F
- Maximum inlet pressure 150 PSI
- No spring in product area
- Single or double seal available
- Seal flush
- All wetted metal components are 316L stainless steel
- Mounted to C-face motor
- Horsepower range to 50 HP

FPR Seal Life Is Measured in Years

Seal life is critical to pump performance. Fristam's unique internal seal uses the cooling and lubrication of the product to provide longer seal life.

The Fristam design also maintains constant pressure between the faces to prevent potential contamination. Even under extreme conditions, Fristam's seal life is often measured in decades.

Some companies have tried to copy Fristam seal designs. None can match the quality and performance of an original Fristam seal.

Material Options:

- Chrome Oxide/Carbon - Standard
- Silicon Carbide/Carbon
- Silicon Carbide/Silicon Carbide
- Chrome Oxide/Silicon Carbide

Easy Shaft Alignment

- Easy installation and maintenance
- Easy gapping
- Concentric alignment, no run-out issues

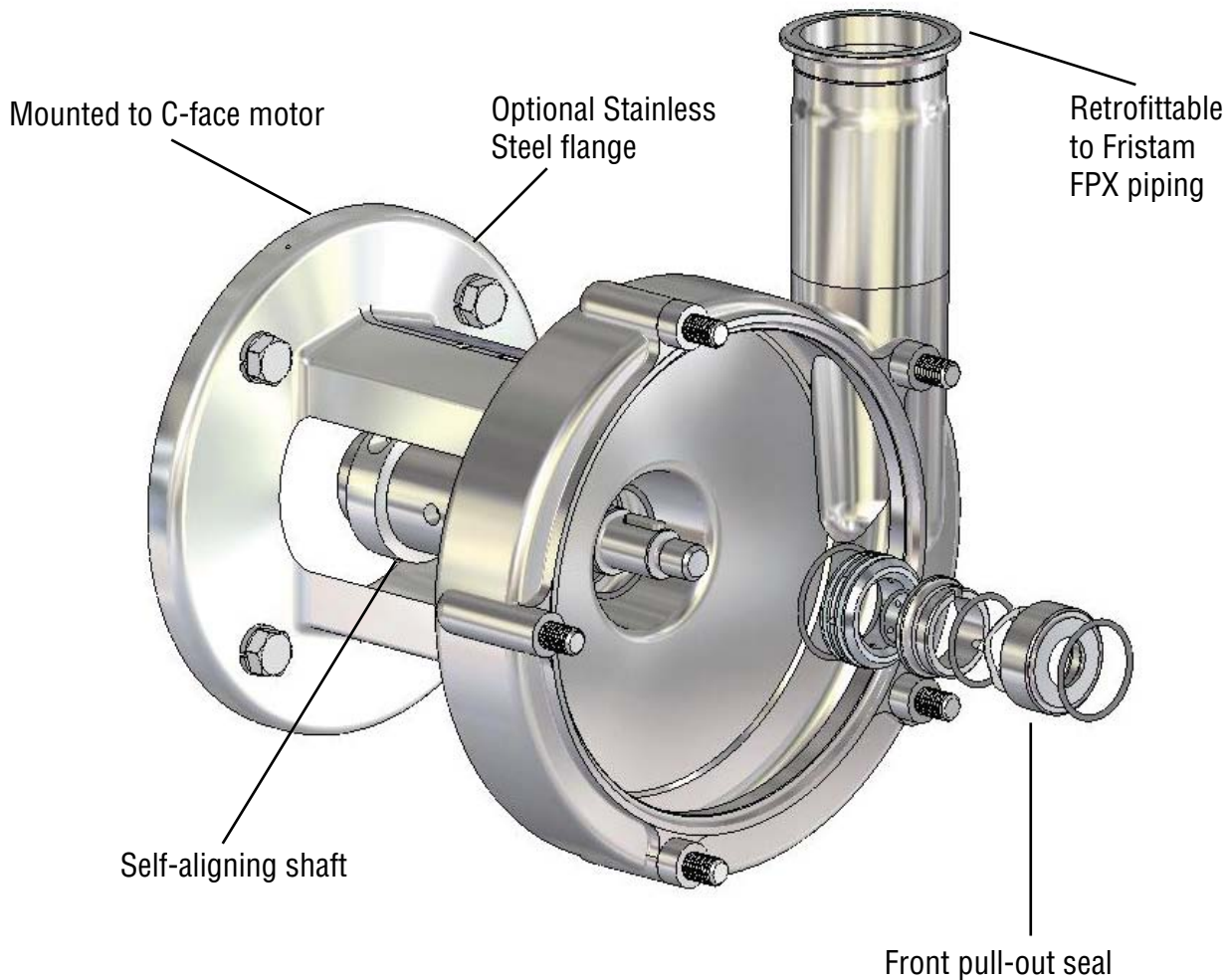

Options



Fittings

Fristam pumps can be supplied with most types of sanitary or industrial fittings. Some alternate inlet sizes are also available. Sanitary fittings must be used on pumps that are required to meet 3-A standards.

Motor Options

Standard motors provided are “Inverter Ready”, TEFC with a locked front bearing. The following options are available:

- Washdown
- Premium Efficiency
- Explosion-Proof
- IEC
- Chemical Duty

Surface Finish

Standard surface finish is 32 Ra. Finer finishes up to 15 Ra and electropolished are available.

Tungsten Carbide Coatings

For extremely abrasive products, internal components can be coated with tungsten carbide to prevent erosion.

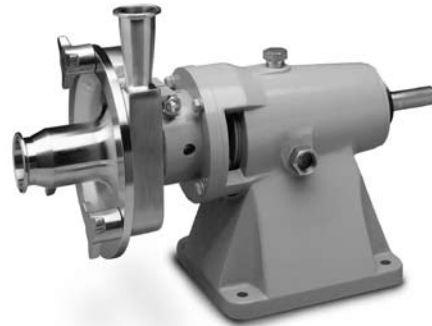

Bearing Blocks

Fristam pumps are available with a bearing block style mounting which can accommodate motors up to 100 HP. The base plate is stainless steel.



Adjustable Base

Fristam Pumps' adjustable bases use solid stainless steel components with adjustable legs.

Stainless Steel Motors/Adapters

Pumps can be provided with stainless steel motors and adapters for protection against corrosive environments and a clean appearance.

Portable Cart

Most Fristam pumps can be mounted on a stainless steel cart, depending on motor size.



FPR Dimensional Drawings

FPR Single Flange Dimensional Drawing

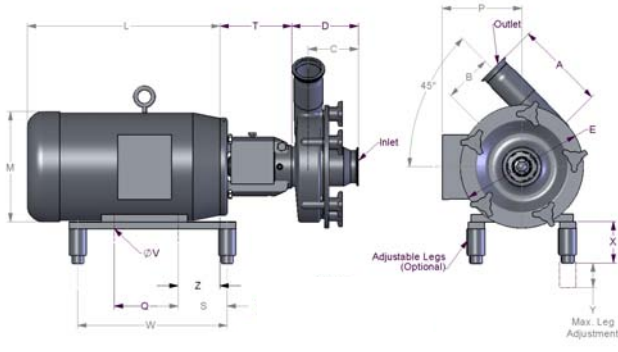

| PUMP MODEL | INLET | OUTLET | A | B | C | D | E |
|-----------------|-------|--------|-------|-------|-------|-------|--------|
| FPR 701/702 | 1.5" | 1.5" | 108 | 44.5 | 106.5 | 139.5 | 150 |
| | | | 4.25" | 1.75" | 4.19" | 5.49" | 5.91" |
| FPR 711/712 | 2" | 1.5" | 144 | 58 | 113 | 145 | 185 |
| | | | 5.67" | 2.28" | 4.45" | 5.71" | 7.28" |
| FPR 721/731/722 | 2" | 1.5" | 170 | 79 | 113 | 145 | 230 |
| | | | 6.69" | 3.11" | 4.45" | 5.71" | 9.06" |
| FPR 741/742 | 2.5" | 2" | 195 | 96 | 101 | 136 | 270 |
| | | | 7.68" | 3.78" | 3.98" | 5.35" | 10.63" |
| FPR 1741/1742 | 2.5" | 2" | 200 | 91 | 104 | 145.5 | 270 |
| | | | 7.87" | 3.58" | 4.09" | 5.73" | 10.63" |
| FPR 3521/3522 | 2.5" | 2" | 190 | 80 | 118 | 157.5 | 230 |
| | | | 7.48" | 3.15" | 4.65" | 6.2" | 9.06" |
| FPR 3531/3532 | 2.5" | 2" | 191 | 95 | 115.5 | 157.5 | 260 |
| | | | 7.52" | 3.74" | 4.55" | 6.2" | 10.24" |
| FPR 3541/3542 | 3" | 2.5" | 211 | 115 | 118 | 157.5 | 290 |
| | | | 8.31" | 4.53" | 4.65" | 6.2" | 11.42" |

| MOTOR HP | | MOTOR FRAME | L | M | N | P | Q | R | S | T | V | W | X | Y | Z | |
|----------|----------|-------------|--------|--------|-------|--------|-------|-------|-------|-------|-------|-------|-------|-------|-------|------|
| 1750 RPM | 3500 RPM | | | | | | | | | | | | | | | |
| 1 HP | 1.5 HP | 143TC | 284 | 175 | 89 | 133 | 101.6 | 4" | 140 | 127 | 120 | 8.7 | 356 | 98 | 38 | 57.2 |
| | | | 11.18" | 6.89" | 3.5" | 5.25" | 4" | 5.5" | 5" | 4.72" | 0.34" | 14" | 3.86" | 1.5" | 2.25" | |
| 1.5 HP | 2 HP | 145TC | 284 | 175 | 89 | 133 | 127 | 140 | 127 | 120 | 8.7 | 356 | 98 | 38 | 57.2 | |
| | | | 11.18" | 6.89" | 3.5" | 5.25" | 5" | 5.5" | 5" | 4.72" | 0.34" | 14" | 3.86" | 1.5" | 2.25" | |
| 2 HP | 3 HP | 145TC | 284 | 175 | 89 | 133 | 127 | 140 | 127 | 120 | 8.7 | 356 | 98 | 38 | 57.2 | |
| | | | 11.18" | 6.89" | 3.5" | 5.25" | 5" | 5.5" | 5" | 4.72" | 0.34" | 14" | 3.86" | 1.5" | 2.25" | |
| 3 HP | 5 HP | 184TC | 340 | 221 | 114 | 149 | 114 | 191 | 108 | 169 | 10.3 | 356 | 98 | 38 | 69.9 | |
| | | | 13.39" | 8.7" | 4.5" | 5.87" | 4.5" | 7.5" | 4.25" | 6.65" | 0.41" | 14" | 3.86" | 1.5" | 2.75" | |
| 5 HP | 7.5 HP | 184TC | 354 | 221 | 114 | 149 | 114 | 191 | 108 | 169 | 10.3 | 356 | 98 | 38 | 69.9 | |
| | | | 13.94" | 8.7" | 4.5" | 5.87" | 4.5" | 7.5" | 4.25" | 6.65" | 0.41" | 14" | 3.86" | 1.5" | 2.75" | |
| 7.5 HP | 10 HP | 213TC | 354 | 221 | 114 | 149 | 140 | 191 | 108 | 169 | 10.3 | 356 | 98 | 38 | 69.9 | |
| | | | 13.94" | 8.7" | 4.5" | 5.87" | 5.5" | 8.5" | 4.25" | 6.65" | 0.41" | 14" | 3.86" | 1.5" | 2.75" | |
| 10 HP | 15 HP | 215TC | 416 | 260 | 133 | 187 | 178 | 216 | 108 | 169 | 10.3 | 356 | 98 | 38 | 88.9 | |
| | | | 16.38" | 10.25" | 5.25" | 7.38" | 7" | 8.5" | 4.25" | 6.65" | 0.41" | 14" | 3.86" | 1.5" | 3.5" | |
| 15 HP | 20 HP | 254TC | 499 | 327 | 159 | 244 | 210 | 254 | 102 | 169 | 13.5 | 406 | 98 | 38 | 108.0 | |
| | | | 19.65" | 12.87" | 6.25" | 9.63" | 8.25" | 10" | 4" | 6.65" | 0.53" | 16" | 3.86" | 1.5" | 4.25" | |
| 20 HP | 25 HP | 284TC | 499 | 327 | 159 | 244 | 254 | 254 | 102 | 169 | 13.5 | 406 | 98 | 38 | 108.0 | |
| | | | 19.65" | 12.87" | 6.25" | 9.63" | 10" | 10" | 4" | 6.65" | 0.53" | 16" | 3.86" | 1.5" | 4.25" | |
| 25 HP | 30 HP | 286TSC | 588 | 371 | 178 | 333 | 241 | 279 | 121 | 179 | 13.5 | 445 | 118 | 45 | 120.7 | |
| | | | 23.15" | 14.63" | 7" | 13.13" | 9.5" | 11" | 4.75" | 7.05" | 0.53" | 17.5" | 4.63" | 1.75" | 4.75" | |
| 30 HP | 40 HP | 324TSC | 588 | 371 | 178 | 333 | 241 | 279 | 121 | 179 | 13.5 | 445 | 118 | 45 | 120.7 | |
| | | | 23.15" | 14.63" | 7" | 13.13" | 9.5" | 11" | 4.75" | 7.05" | 0.53" | 17.5" | 4.63" | 1.75" | 4.75" | |
| 40 HP | 50 HP | 326TSC | 636 | 419 | 203 | 359 | 267 | 318 | 121 | 179 | 16.7 | 470 | 118 | 45 | 133.4 | |
| | | | 25.04" | 16.5" | 8" | 14.13" | 10.5" | 12.5" | 4.75" | 7.05" | 0.66" | 18.5" | 4.63" | 1.75" | 5.25" | |
| 50 HP | 75 HP | 326TC | 636 | 419 | 203 | 359 | 305 | 318 | 121 | 179 | 16.7 | 470 | 118 | 45 | 133.4 | |
| | | | 25.04" | 16.5" | 8" | 14.13" | 12" | 12.5" | 4.75" | 7.05" | 0.66" | 18.5" | 4.63" | 1.75" | 5.25" | |

FPR Double Flange Dimensional Drawing

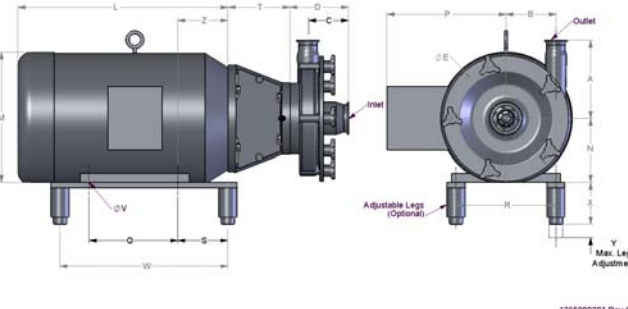

| PUMP MODEL | INLET | OUTLET | A | B | C | D | E |
|---------------|-------|--------|-------|-------|-------|-------|--------|
| FPR 751/752 | 3" | 2" | 205 | 145 | 99 | 142 | 379 |
| | | | 8.07" | 5.71" | 3.9" | 5.59" | 14.92" |
| FPR 3451/3452 | 3" | 2" | 211 | 140 | 114 | 160.5 | 350 |
| | | | 8.31" | 5.51" | 4.49" | 6.32" | 13.78" |
| FPR 3551/3552 | 3" | 2.5" | 230 | 140 | 119 | 170 | 350 |
| | | | 9.06" | 5.51" | 4.89" | 6.69" | 13.78" |
| FPR 1051 | 4" | 4" | 250 | 170 | 107 | 202.5 | 406 |
| | | | 9.84" | 6.69" | 6.57" | 7.97" | 15.98" |
| FPR 1161 | 4" | 4" | 250 | 170 | 110.5 | 146 | 406 |
| | | | 9.84" | 6.69" | 4.35" | 5.75" | 15.98" |

| MOTOR HP | | MOTOR FRAME | L | M | N | P | Q | R | S | T | V | W | X | Y | Z |
|----------|----------|-------------|--------|--------|-------|--------|--------|-------|-------|-------|-------|-------|-------|-------|-------|
| 1750 RPM | 3500 RPM | | | | | | | | | | | | | | |
| 3 HP | 5 HP | 182TC | 313 | 221 | 114 | 149 | 114 | 191 | 108 | 160 | 10.3 | 356 | 98 | 38 | 69.9 |
| | | | 12.32" | 8.7" | 4.5" | 5.87" | 4.5" | 7.5" | 4.25" | 6.3" | 0.41" | 14" | 3.86" | 1.5" | 2.75" |
| 5 HP | 7.5 HP | 184TC | 347 | 221 | 114 | 149 | 140 | 191 | 108 | 160 | 10.3 | 356 | 98 | 38 | 69.9 |
| | | | 13.68" | 8.7" | 4.5" | 5.87" | 5.5" | 7.5" | 4.25" | 6.3" | 0.41" | 14" | 3.86" | 1.5" | 2.75" |
| 7.5 HP | 10 HP | 213TC | 386 | 221 | 114 | 149 | 140 | 191 | 108 | 160 | 10.3 | 356 | 98 | 38 | 69.9 |
| | | | 15.2" | 8.7" | 4.5" | 5.87" | 5.5" | 7.5" | 4.25" | 6.3" | 0.41" | 14" | 3.86" | 1.5" | 2.75" |
| 10 HP | 15 HP | 215TC | 388 | 260 | 133 | 187 | 140 | 216 | 108 | 160 | 10.3 | 356 | 98 | 38 | 88.9 |
| | | | 15.28" | 10.25" | 5.25" | 7.38" | 5.5" | 8.5" | 4.25" | 6.3" | 0.41" | 14" | 3.86" | 1.5" | 3.5" |
| 15 HP | 20 HP | 254TC | 436 | 260 | 133 | 187 | 178 | 216 | 108 | 160 | 10.3 | 356 | 98 | 38 | 88.9 |
| | | | 17.17" | 10.25" | 5.25" | 7.38" | 7" | 8.5" | 4.25" | 6.3" | 0.41" | 14" | 3.86" | 1.5" | 3.5" |
| 20 HP | 25 HP | 284TC | 447 | 327 | 159 | 244 | 210 | 254 | 102 | 160 | 13.5 | 406 | 98 | 38 | 108 |
| | | | 17.6" | 12.87" | 6.25" | 9.63" | 8.25" | 10" | 4" | 6.3" | 0.53" | 16" | 3.86" | 1.5" | 4.25" |
| 25 HP | 30 HP | 286TSC | 499 | 327 | 159 | 244 | 254 | 254 | 102 | 160 | 13.5 | 406 | 98 | 38 | 108 |
| | | | 19.65" | 12.87" | 6.25" | 9.63" | 10" | 10" | 4" | 6.3" | 0.53" | 16" | 3.86" | 1.5" | 4.25" |
| 30 HP | 40 HP | 324TSC | 588 | 371 | 178 | 333 | 241 | 279 | 121 | 174 | 13.5 | 445 | 118 | 45 | 121 |
| | | | 23.15" | 14.63" | 7" | 13.13" | 9.5" | 11" | 4.75" | 6.85" | 0.53" | 17.5" | 4.63" | 1.75" | 4.75" |
| 40 HP | 50 HP | 326TSC | 588 | 371 | 178 | 333 | 241 | 279 | 121 | 174 | 13.5 | 445 | 118 | 45 | 121 |
| | | | 23.15" | 14.63" | 7" | 13.13" | 9.5" | 11" | 4.75" | 6.85" | 0.53" | 17.5" | 4.63" | 1.75" | 4.75" |
| 50 HP | 75 HP | 326TC | 636 | 419 | 203 | 359 | 267 | 318 | 121 | 209 | 16.7 | 470 | 118 | 45 | 133 |
| | | | 25.04" | 16.5" | 8" | 14.13" | 10.5" | 12.5" | 4.75" | 7.05" | 0.66" | 18.5" | 4.63" | 1.75" | 5.25" |
| 75 HP | 100 HP | 364TC | 685 | 470 | 229 | 383 | 286 | 356 | 89 | 209 | 16.7 | 508 | 127 | 45 | 149 |
| | | | 26.97" | 18.5" | 9" | 15.06" | 11.25" | 14" | 3.5" | 8.23" | 0.66" | 20" | 5" | 1.75" | 5.87" |
| 100 HP | 150 HP | 365TC | 685 | 470 | 229 | 383 | 286 | 356 | 89 | 209 | 16.7 | 508 | 127 | 45 | 149 |
| | | | 26.97" | 18.5" | 9" | 15.06" | 11.25" | 14" | 3.5" | 8.23" | 0.66" | 20" | 5" | 1.75" | 5.87" |
| 150 HP | 200 HP | 365TSC | 685 | 470 | 229 | 383 | 311 | 356 | 89 | 209 | 16.7 | 508 | 127 | 45 | 149 |
| | | | 26.97" | 18.5" | 9" | 15.06" | 12.25" | 14" | 3.5" | 8.23" | 0.66" | 20" | 5" | 1.75" | 5.87" |

FPR Double Flange Dimensional Drawing – Model 4001

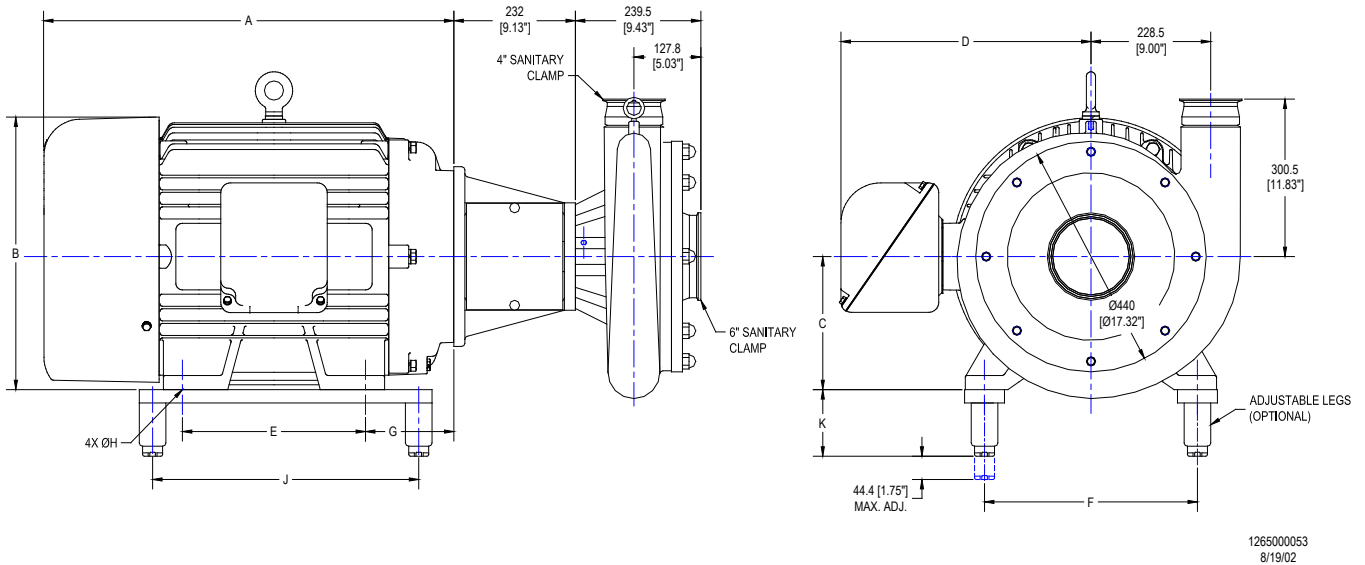

| MOTOR HP | MOTOR FRAME | DIMENSIONS IN MILLIMETERS (INCHES) | | | | | | | | | |
|----------|-------------|------------------------------------|-----------------|-----------------|-----------------|-----------------|-----------------|----------------|------------------|-----------------|----------------|
| | | A | B | C | D | E | F | G | ØH | J | K |
| 40 HP | 324TC | 636 (25.05") | 418 (16.44") | 203 (8.00") | 371 (14.62") | 267 (10.50") | 317 (12.50") | 133 (5.25") | 16.7 (21/32") | 470 (18.50") | 117 (4.63") |
| 50 HP | 326TC | 636 (25.05") | 418 (16.44") | 203 (8.00") | 371 (14.62") | 305 (12.00") | 317 (12.50") | 133 (5.25") | 16.7 (21/32") | 470 (18.50") | 117 (4.63") |
| 60 HP | 364TC | 684 (26.94") | 470 (18.50") | 229 (9.00") | 380 (14.95") | 286 (11.25") | 355 (14.00") | 149 (5.88") | 16.7 (21/32") | 508 (20.00") | 127 (5.00") |
| 75 HP | 365TC | 684 (26.94") | 470 (18.50") | 229 (9.00") | 380 (14.95") | 311 (12.25") | 355 (14.00") | 149 (5.88") | 16.7 (21/32") | 508 (20.00") | 127 (5.00") |
| 100 HP | 405TC | 782 (30.80") | 520 (20.48") | 254 (10.00") | 477 (18.78") | 349 (13.75") | 406 (16.00") | 168 (6.62") | 20.6 (13/16") | 508 (20.00") | 127 (5.00") |

1265000054
8/19/02

FPR Sanitary Pump Composite Performance Curve

Speed: 1750 rpm (60 Hertz)

Performance curves based on tests using 70°F water. A tolerance of ±5% applies to all figures.
 For vacuum withdrawal applications, please contact Fristam Pumps, USA.

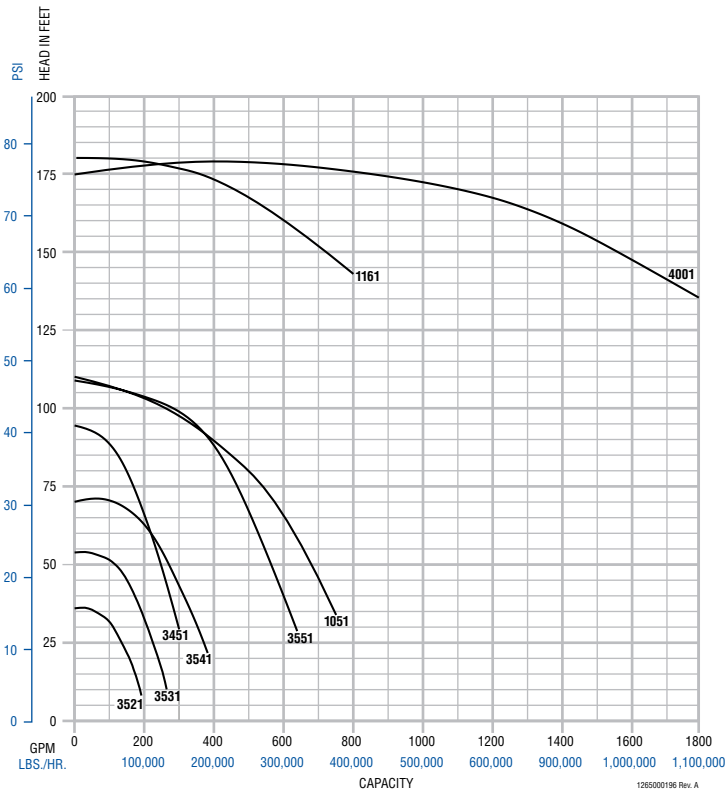
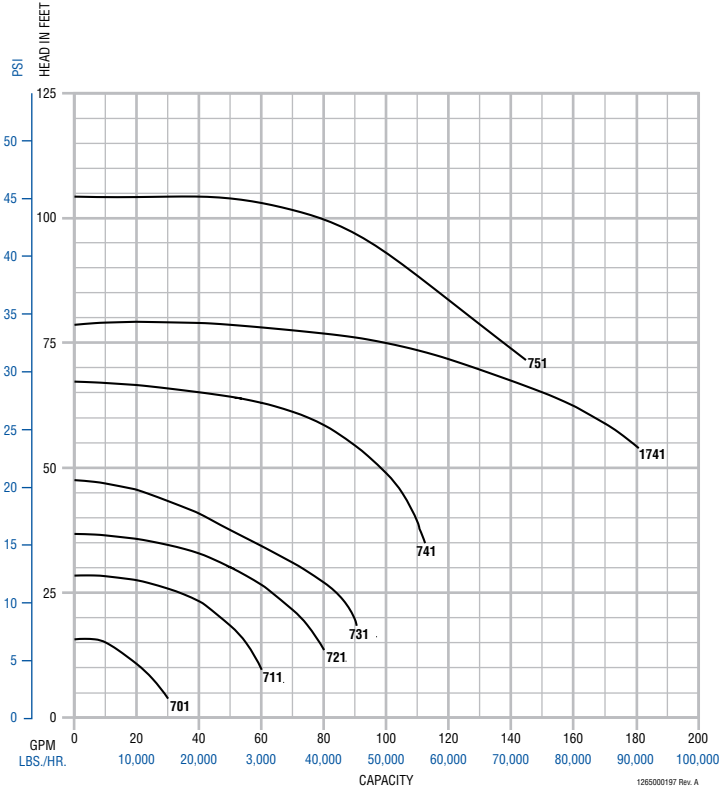

FPR Sanitary Pump Composite Performance Curve

Speed: 3500 rpm (60 Hertz)

Performance curves based on tests using 70°F water. A tolerance of ±5% applies to all figures.
 For vacuum withdrawal applications, please contact Fristam Pumps, USA.

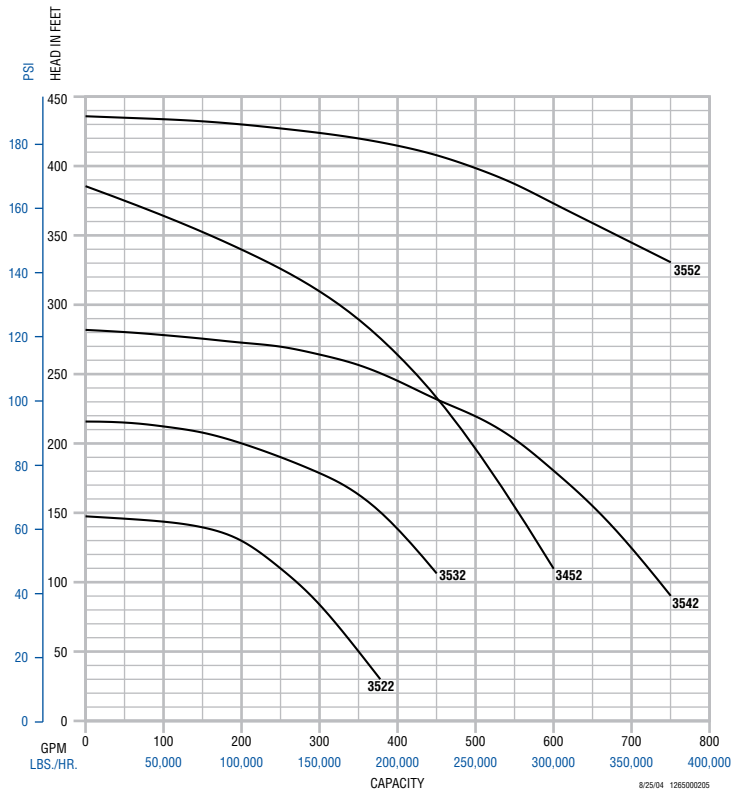
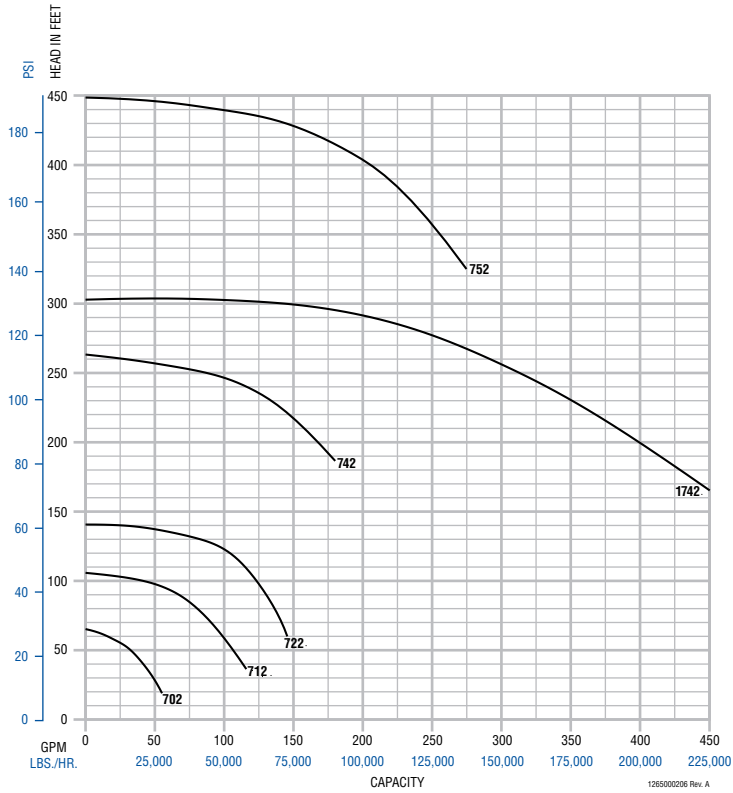

Specialty Pumps



Water for Injection

The Fristam WFI pump is a precision adaptation of the FPR Series pump. Fristam pioneered the “Double Safe Seal System” to ensure product sterility. Its low pressure, low flush design protects product sterility and saves valuable product.



Aseptic Centrifugal

Aseptic processing requires equipment which assures both product dependability and sterility. The Fristam FPR double-seal pump offers a perfect fit for aseptic processing. With sterile barriers at all seal points, including the cover gasket, your product is protected from contamination.



Jacketed Pump Housing

Fristam’s jacketed pump housing is available on most FPR models. The jacketed pump housing is designed for products that require temperature control. This includes applications that require heated products, such as chocolate, to remain liquid and not solidify or for applications that require a cold product, such as brewing.

Other Superior Quality Fristam Products



FKL



FL II

Positive Displacement Pumps

- Heavy-duty FKL Series pumps are fully CIP'able without performance loss, operate at up to 300 PSI and handle viscosities to one million cps.
- Standard-duty FL II Series pumps reduce product damage through low pulsation and gentle handling. Their bi-wing rotor simplifies maintenance and allows for CIP/SIP cleaning.



FM 5

High-Pressure Centrifugal Pumps

- FM multi-stage pumps have become the benchmark for reverse osmosis system pumps with a non-pulsating flow and lower maintenance costs. FM pumps can operate at discharge pressures up to 340 PSI and inlet pressures up to 750 PSI.
- FPH and FPHP Series high-pressure pumps supplement the operating capability of the Fristam multi-stage product line. FPH and FPHP Series pumps operate with discharge pressures to 1,250 PSI.



FZX

Liquid Ring Pumps

Ideal for CIP solution and foamy or aerated products, Fristam's FZX Series pumps reduce waste by completely removing product from process equipment. Fully CIP'able/SIP'able, the FZX series has a maximum inlet pressure of 150 PSI.



FS

Shear Blenders

FS Series blenders improve product consistency by removing agglomerates and preventing lumps and masses in product. Use the FS Series to blend, emulsify, disperse, dissolve, texturize and homogenize. CIP'able/SIP'able, it saves processors time and money, in addition to improving product quality.



Powder Mixer

Powder Mixers

Fristam's Powder Mixer's unique two pump system provides quick, high-performance blending of wet and dry ingredients into a fluid stream. It's easy to use and saves time and money.

The rotor-stator design of the FS Series Shear Blender eliminates unblended product and prevents lumps and masses for consistent batch-to-batch repeatability. The self-priming FZX Liquid Ring Pump creates a consistent vacuum at the bottom of the funnel to prevent plugging and maintain powder rate, even as viscosity increases.

Worldwide Contact Details

North America/ South America

Fristam Pumps USA
P.O. Box 620065
2410 Parview Road
Middleton, WI 53562-2524

TEL: 1-608-831-5001
1-800-841-5001
FAX: 1-608-831-8467

www.fristam.com
fristam@fristampumps.com



Belgium/Luxembourg
Fristam N.V.
Aartselaar

France
Pompes Fristam S.A.
Noisy-le-Sec

Germany
Fristam Pumpen F. StampKG
(GmbH & Co)
Hamburg

Great Britain
Fristam Pumps (UK) Ltd.
Hailsham

India
Fristam Pumps (I) Pvt. Ltd.
Pune

Italy
Fristam Italia S.r.l.
Borgo Ticino (NO)

Japan
Stamp Pumps of Japan Ltd.
Tokyo

Netherlands
Fristam B.V.
De Meern

New Zealand
Fristam Pumps Ltd.
Cambridge

Peoples Republic of China
Fristam Pumps (Shanghai) Co. Ltd.
Shanghai

Poland
Fristam Polska sp.z.o.o.
Warsaw

Russian Federation
Fristam Pumpen R.A.
Moscow

Scandinavia
Fristam Pumper A/S
Saeby

S.E. Asia
Fristam Pumpen A.R.
Singapore

Spain/Portugal
Fristam Iberica S.L.
Barcelona

Fristam's Commitment

Fristam Pumps manufactures the sturdiest products in the industry. Our design reduces repair/replacement cost, downtime and energy consumption, and therefore yields high lifetime value. Fristam is one of the most accessible equipment companies in the world. Fristam's dedication and quality service do not end with your initial purchase. An international network of manufacturing facilities, sales offices and distribution supports Fristam's commitment to customer satisfaction.

3-A, GMP, U.S.D.A., F.D.A., ISO and EHEDG

Fristam complies with and supports regulatory standards. Fristam pumps meet all applicable industry standards for performance, cleanliness and design. As a registered ISO 9001:2000 company, Fristam is committed to consistent quality products.



Visit www.fristam.com for
a current list of literature

Fristam
PUMPS

Re-order #1050000181 R5
©2007 Fristam Pumps USA