

omd 800-648-3326
oliver m. dean, inc. www.omdean.com

DDI

Dosing

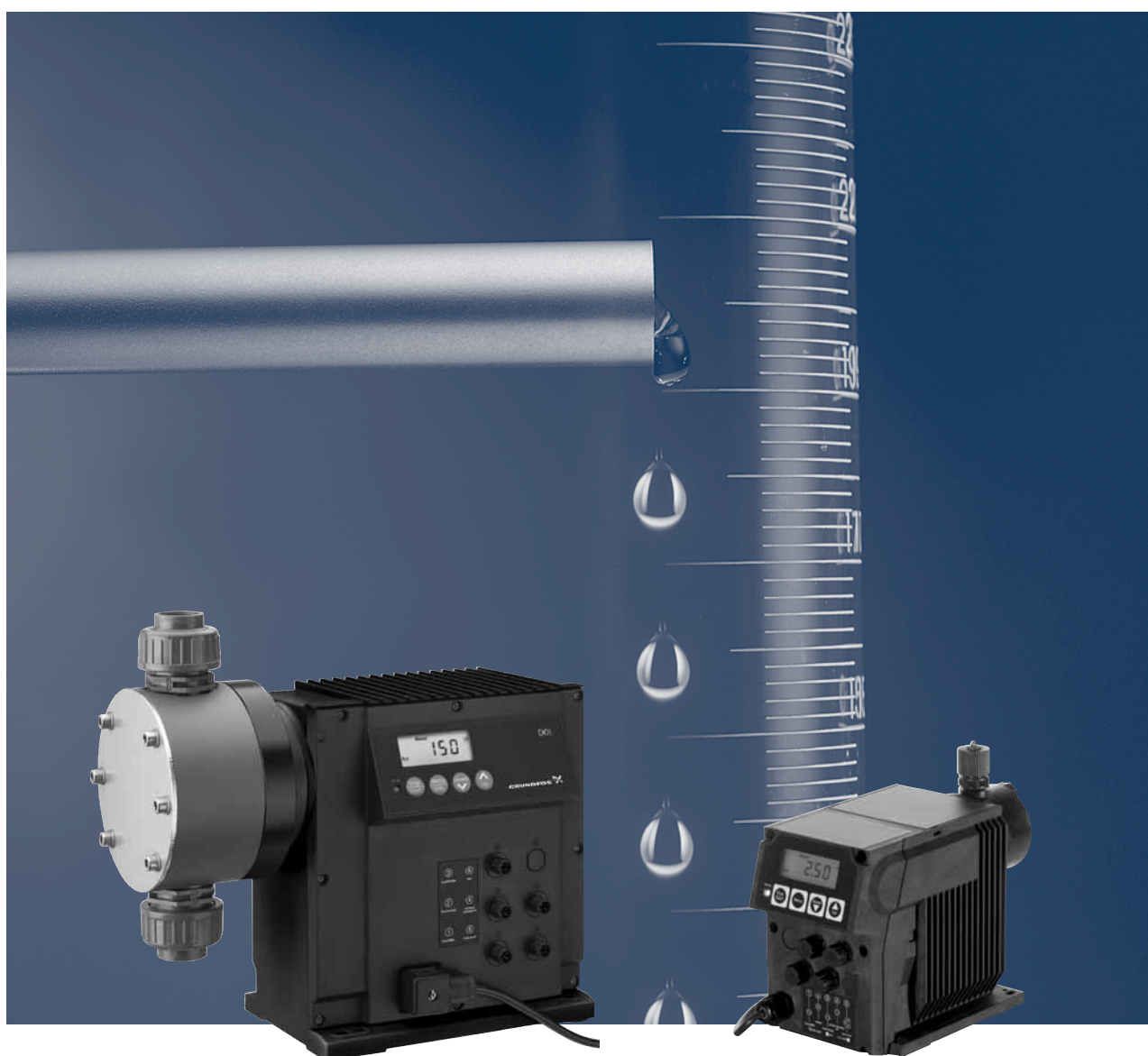

Contents

Features and benefits

DDI 209	3
DDI 222	4

Performance range

DDI AR	5
DDI 209 AR and AM with Plus3	6

Identification

Type key	7
----------	---

Functions

Versions	8
Options	8
Capacity control	9
Control panel	9
Menu	10
Operating modes	12
Other options	12

Construction

General description	14
DDI 209	14
DDI 222 AR	14
DDI 209 AR with manual vent valve	14
DDI 222 AR	15
DDI 209 AR with Plus3 system	16
DDI 209 AM	17
Functional principle of the Plus3 system	18
Spring-loaded valves	18
DDI AR with leak detection	19

Technical data

Dimensions	20
Performance data	25
Suction lift	26
Permissible viscosity	27
Inlet and discharge pressures	28
Permissible temperature range of the pumped media	28
Weights	29
Electrical data	29
Additional technical data	29
Electronic functions	30
Operating modes, additional data	31

Pump selection

DDI selection (0.106 to 39.6 GPH)	32
-----------------------------------	----

Pumped liquids

List of pumped liquids	34
------------------------	----

Further product documentation

WebCAPS	35
WinCAPS	36

DDI 209

DIGITAL DOSING

up to 5.28 GPH



GrA1080p

Fig. 1 DDI 209

The difference is digital

The Grundfos DDI range was created because accurate dosing demands precision. But it need not be hard work. These compact units combine perfect precision with a user interface that lets you set the dosing rate you want directly on the unit – without spending time on complicated calculations beforehand. Available materials include PVC, PVDF, polypropylene and 316 stainless steel.

The DDI AR: Taking diaphragm dosing pumps to the next level

The DDI AR series is the backbone of the overall DDI range. Its innovative drive technology combines a powerful stepper motor with integrated contact signal control to bring you smoother, more accurate dosing. The user interface gives you a full range of options for customizing the dosing process.

The DDI AM: Three-in-one dosing

The DDI AM models have all of the overall DDI benefits and bring you three-in-one dosing: it doses, measures, regulates and self calibrates all by itself. It eliminates the need for additional equipment by combining precision dosing, continuous flow measurement, and set-point monitoring in a single unit.

Does the hard work for you

The DDI range eliminates the need for extensive calculation work associated with other dosing equipment.

You won't need to work out how many strokes per minute are necessary to give you the desired dosing rate – simply enter the figure you want in the user interface, and the DDI does the work for you.

Smooth dosing through variable speed

The Grundfos DDI never rushes things. It has an ingenious stepper motor that extends the discharge phase throughout the full period between suction phases. In other words, it automatically adjusts the dosing speed to provide the right amount of additive at all times. No jerky movements here – just smooth, even dosing.

Full stroke length at all times

The Grundfos DDI does not pull punches: it uses a full stroke length every time, thereby eliminating potential disruptive factors such as gas build-up. Rather than adjusting the stroke length by shortening it to suit dosing demand, the Grundfos DDI carefully times each full stroke to ensure even concentrations of additive in your media.

Turndown ratio 1:100

The DDI range is designed to give you superior flexibility and accuracy with as few product variants as possible. That is why you can adjust dosing rates within a 1:100 scale without any loss of dosing accuracy: the DDI series can dose additive in quantities down to 0.0066 GPH with perfect precision – and evidence of this precision can be provided at any time while the pump is running.

Reliable dosing of viscous liquids

When you wish to dose viscous liquids, many conventional dosing pumps struggle to maintain reliability. By contrast, the DDI series has a special "slow mode" function which decelerates the suction stroke. This maintains reliable dosing.

Examples of applications

- Treatment of industrial and municipal water
- Industrial cleaning
- Polymer feed
- Paper production/paper finishing
- Optical technology and chip production
- Chemical industry
- CIP cleaning and disinfection
- Galvanic industry and surface treatment
- Air conditioning/cooling towers
- Reverse osmosis systems
- Semi-conductor industry.

DDI 222

DIGITAL DOSING

up to 39.6 GPH



TM 03.4770.2706

Fig. 2 DDI 222 AR

The DDI series is well established on the dosing pump market with its combination of innovative drive technology and integrated microelectronics. Users appreciate how they can simply enter the required dosing rate in liters per hour and let the DDI handle the rest.

Flow monitor checks for malfunctions - optional

The unique flow monitor detects any dosing errors on both the suction and pressure sides and immediately emits an error message if anything is wrong. It can also check for excess pressure: Just enter the maximum back pressure allowed (in bar) and leave everything to the DDI. If the pressure is exceeded, the pump shuts down.

Double diaphragm for optimal process reliability - optional

Some processes must never be interrupted - not even in the event of a diaphragm rupture. The DDI is available with an integrated double diaphragm system with a differential pressure sensor. If the diaphragm fails, the DDI will continue dosing thanks to the protective diaphragm, send an error signal as notification to replace the diaphragm.

Turndown ratio 1:800

The DDI 222 AR has a turndown ratio ten times better than that of traditional equipment, allowing us to create a complete pump series with just one motor, one gearing system, and two pump head sizes. You get the precision you want every time - and need only a minimum of spare parts and storage capacity.

Compact design

DDI pumps are smaller and quieter than conventional pumps in their class, making them easy to install anywhere. Order your DDI with the control and display interface on the side or front as you wish.

Full stroke length every time

The DDI series use a full stroke length every time - a feature unique to Grundfos dosing pumps. Each stroke is carefully timed to bring you even concentrations in the system and optimal priming throughout the entire operating range.

Brushless DC motor

The drive solution used in the DDI series ensures very smooth, continuous dosing even as it keeps energy consumption at a record low.

Anti-cavitation function

The "slow mode" settings systematically reduce the suction stroke so that difficult, viscous media are dosed with smooth precision. When set at 60% of the maximum dosing rate, the DDI can dose liquids with a viscosity of up to 1,000 cps; at 40%, it will handle extremely viscous media up to 2600 cps. You no longer need external dilution or treatment systems, but can dose chemicals directly and with no waste.

Fieldbus communication available

The DDI is also available with a Profibus DP interface.

Switch-mode power supply

DDI pumps can be used worldwide within the 100-240 VAC, 50/60 Hz range.

DDI AR

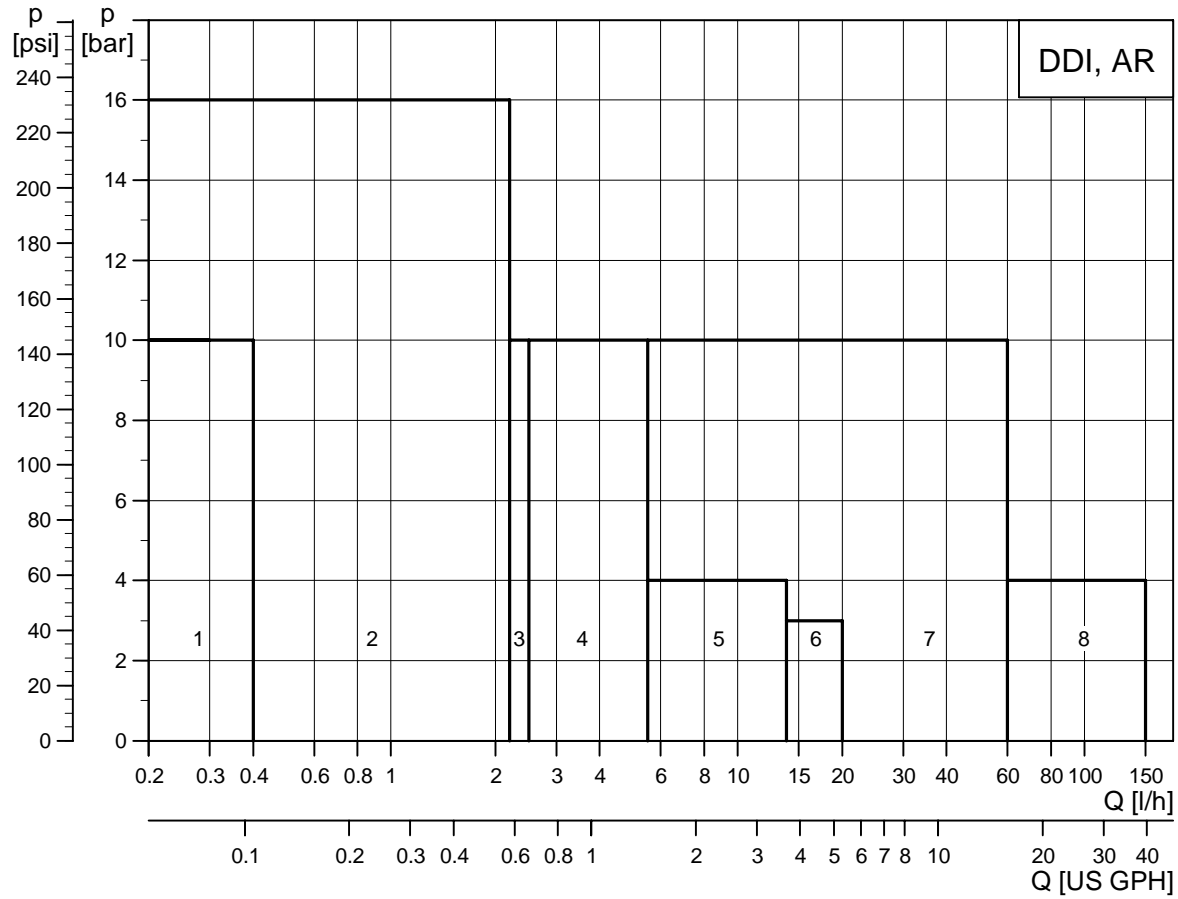

TM03 3444 2106

Fig. 1 Performance range, DDI AR

Pos.	Pump	Model
1	DDI 0.4 - 10	209 AR
2	DDI 2 - 16	209 AR
3	DDI 3 - 10	209 AR
4	DDI 6 - 10	209 AR
5	DDI 14 - 4	209 AR
6	DDI 20 - 3	209 AR
7	DDI 60 - 10	222 AR
8	DDI 150 - 4	222 AR

DDI 209 AR and AM with Plus³

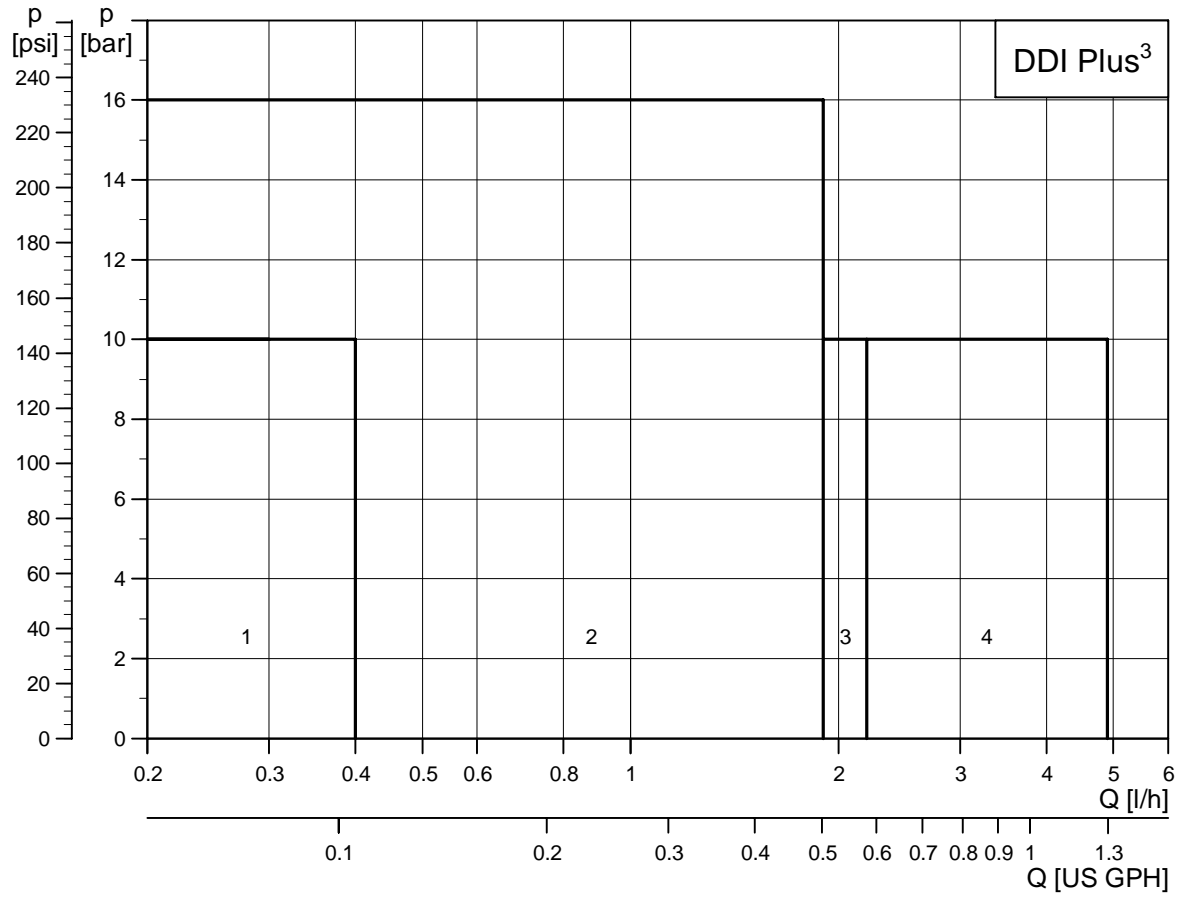

TM03 3443 2106

Fig. 2 Performance range, DDI 209 AR and AM with Plus³

Pos.	Pump	Model
1	DDI 0.4 - 10	209 AM and 209 AR with Plus ³
2	DDI 2 - 16	209 AM and 209 AR with Plus ³
3	DDI 3 - 10	209 AM and 209 AR with Plus ³
4	DDI 6 - 10	209 AM and 209 AR with Plus ³

Type key

Example:	DDI	2-16	AR	PVC	/V	/G	-F	-3	1	3	B1	B	
Type range													
DDI													
Size													
Control version													
AR	Standard												
AM	AR with Plus ³ and continuous calibration												
AF	AR with flow monitor												
AP	AR with Profibus												
APM	AM with Profibus												
APF	AR with flow monitor and Profibus												
Dosing head variant													
PP	Polypropylene												
PV	PVDF (polyvinylidene fluoride)												
PVC	Polyvinyl chloride												
SS	Stainless steel 316												
PP-P3	PP + Plus ³												
PVC-P3	PVC + Plus ³												
PP-L	PP + Integrated diaphragm leakage detection												
PV-L	PV + Integrated diaphragm leakage detection												
PVC-L	PVC + Integrated diaphragm leakage detection												
SS-L	SS + Integrated diaphragm leakage detection												
Gasket material													
E	EPDM (ethylene propylene diene monomer)												
V	FKM (fluorocarbon, e.g. Viton®)												
T	PTFE (polytetrafluoroethylene, e.g. Teflon®)												
Valve ball material													
C	Ceramic												
G	Glass												
T	PTFE (polytetrafluoroethylene, e.g. Teflon®)												
SS	Stainless steel 316												
Control panel position													
F	Front-mounted												
T	Top-mounted												
S	Side-mounted												
												Mains plug	
												X	No plug
												F	EU (Schuko)
												B	USA, Canada
												I	Australia, New Zealand, Taiwan
												E	Switzerland
													Connection, suction/discharge
												B6	Pipe 4/6 mm
												3	Tube 4/6 mm
												A5	Tube 5/8 mm
												4	Tube 6/9 mm
												6	Tube 9/12 mm
												Q	Tube 19/27 mm
												C4	Tube 1/8" / 1/4"
												R	Tube 1/4" / 3/8"
												S	Tube 3/8" / 1/2"
												A	Threaded Rp 1/4"
												A1	Threaded Rp 3/4", female
												V	Threaded NPT 1/4"
												A9	Threaded NPT 1/2", male
												A3	Threaded NPT 3/4", female
												A7	Threaded NPT 3/4", male
												B1	Tube 6/12 mm/cementing d. 12 mm
												B2	Tube 13/20 mm/cementing d. 25 mm
												B3	Welding d. 16 mm
												B4	Welding d. 25 mm
													Valve type
												1	Standard
													Spring-loaded
												2	0.7 psi inlet opening pressure
													0.7 psi discharge opening pressure
													Spring-loaded
												3	0.7 psi inlet opening pressure
													11.6 psi discharge opening pressure
												4	Spring-loaded discharge
													11.6 psi discharge opening pressure
												5	For abrasive media (SS only)
													Spring-loaded discharge
												6	(DN 20, SS balls)
													11.6 psi discharge opening pressure
													Supply voltage
												3	1 x 100-240 V, 50/60 Hz
												I	24 VDC

Versions

Features	Control versions					
	AR	AM	AF	AP	APM	APF
Flow monitor			•			•
Flow measurement		•			•	
Profibus communication				•	•	•



Fig. 1 DDI 209 AR



Fig. 2 DDI 222 AR

GrA1080p

TM03-4770 2706

Options

Pump	Control versions					
	Standard	AR with Plus ³ and continuous calibration	AR with flow monitor	AR with Profibus	AM with Profibus	AR with flow monitor and Profibus
	AR	AM	AF	AP	APM	APF
DDI 0.4 - 10	•	•	•	•	•	•
DDI 2 - 16	•	•	•	•	•	•
DDI 3 - 10	•	•	•	•	•	•
DDI 6 - 10	•	•	•	•	•	•
DDI 14 - 4	•		•	•		•
DDI 20 - 3	•		•	•		•
DDI 60-10	•		•	•		•
DDI 150-4	•		•	•		•

Pump	Pump heads			Additional options		
	AR + Plus ³	AF + Plus ³	Leak tetection	Top control panel	Spring-loaded valves (HV)	24 V DC motor
DDI 0.4 - 10	•	•	•	•	•	•
DDI 2 - 16	•	•	•	•	•	•
DDI 3 - 10	•	•	•	•	•	•
DDI 6 - 10	•	•	•	•	•	•
DDI 14 - 4			•	•	•	•
DDI 20 - 3			•	•	•	•
DDI 60-10			•		•	
DDI 150-4			•		•	

Capacity control

The stepper motor of the DDI 209, provides full control of the stroke speed.

The DDI 222, has an EC motor (brushless DC motor) and electronic power control. Please see page 25 for performance data.

As shown in the figure below, the duration of each suction stroke is constant (while the duration of each discharge stroke varies according to the set capacity).

This has many advantages:

- The full stroke length reduces gas build-up in the dosing head.
- Even and constant dosing ensures an optimum mixing ratio at the injection point.
- Significant reduction of pressure surges prevents mechanical stress on diaphragm, tubes, connections and other dosing parts.
- The installation is less affected by long suction and discharge lines.
- Dosing of highly viscous and volatile liquids is easier.

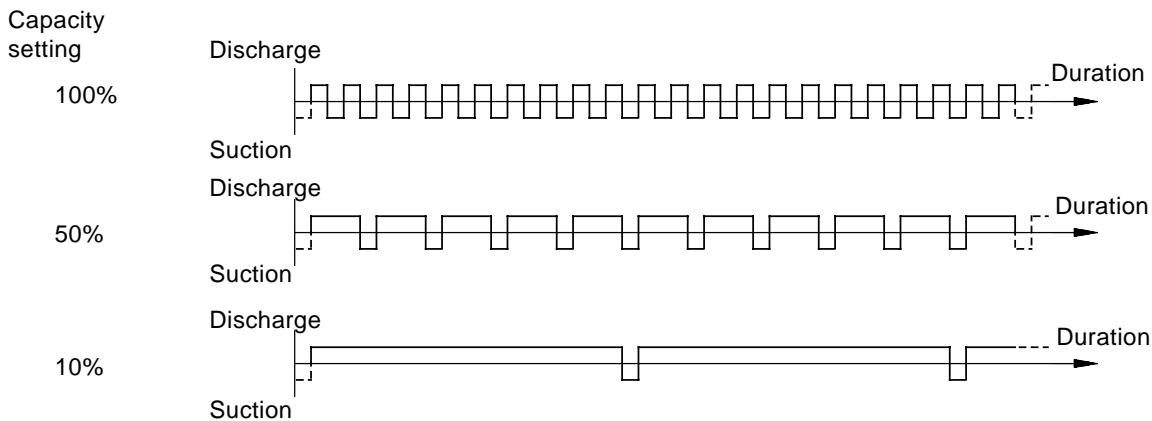

Fig. 3 Relation between discharge stroke speed and capacity

TM03 2074 3505

Control panel

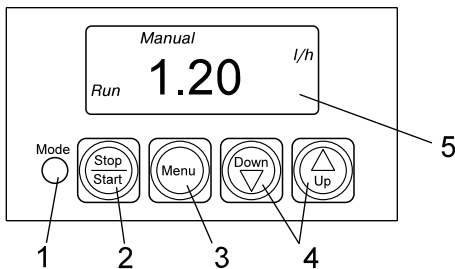

Fig. 4 DDI control panel

TM03 4455 2106

Legend

Pos.	Component
1	Mode (light-emitting diode): <ul style="list-style-type: none"> • Red light indicates that the pump has stopped. • Green light indicates that the pump has started; the light is briefly off during a suction stroke. • Yellow light indicates that the pump is switched off remotely • Red light is flashing in case of an error signal • Light is off when the pump is in menu mode
2	Start/stop (button): <ul style="list-style-type: none"> • For starting and stopping the pump.
3	Menu (button): <ul style="list-style-type: none"> • For switching between operating modes.
4	Down/Up (button): <ul style="list-style-type: none"> • For changing the values in the display.
5	LCD display

Menu

Menu, first level

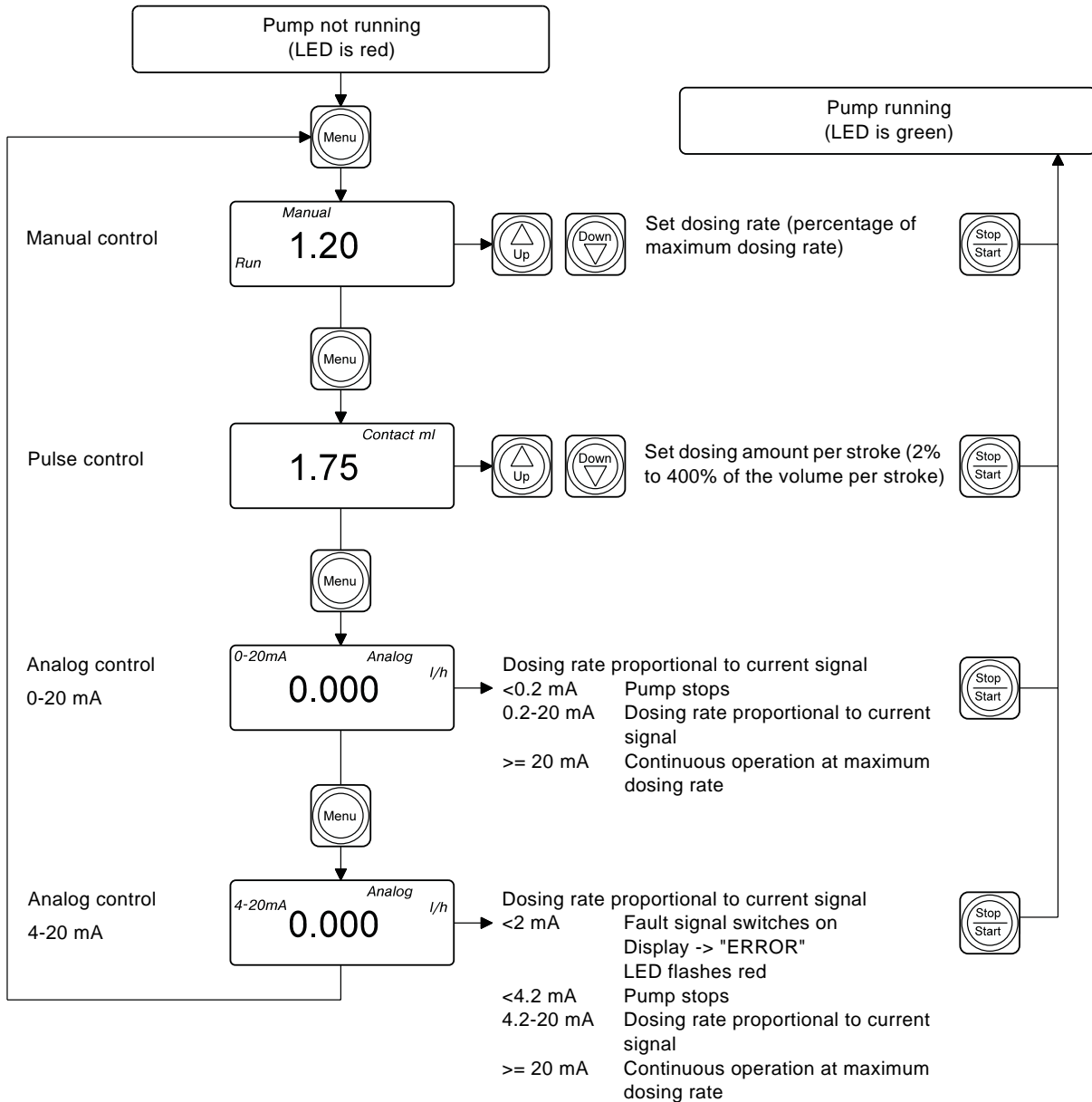
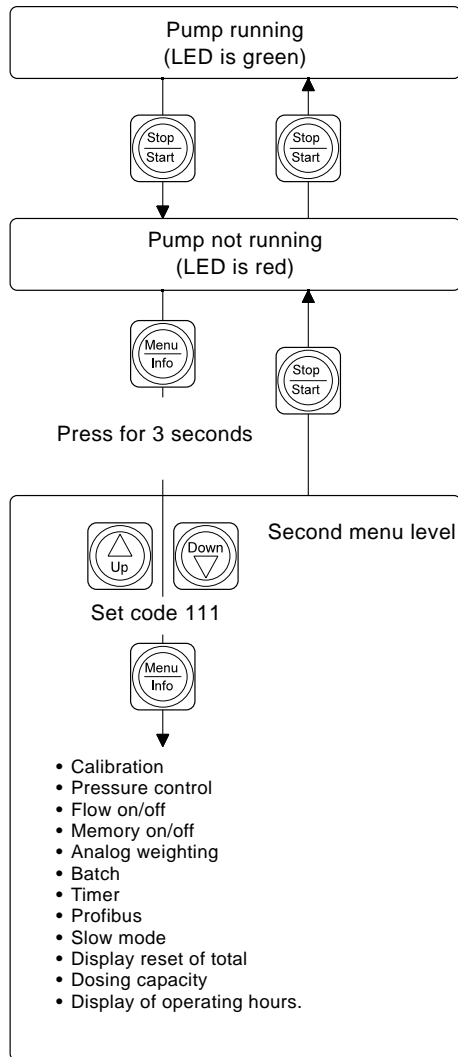

Fig. 5 Menu (first level)

TM03 4453 2106

Menu, second level

Please see the pump manual for a detailed overview and instructions for navigating the menu.



TM03 4454 2106

Fig. 6 Menu (second level)

Menu, third level

The third level is for setting the pump type and the dosing flow measuring unit (l/h or gal/h) as well as for setting the inputs and outputs.

Operating modes

Manual control

In manual control mode, the flow rate is set in the display.

Pulse control

For each pulse received at the contact input of the pump (for example from a water meter with reed contact output), the pump doses the set quantity. The memory can store a maximum of 65000 pulses for processing later,

Analog control

The dosed quantity is proportional to the current input signal of 0-20 mA or 4-20 mA.

Batch mode

In batch mode, a defined batch quantity is dosed with a defined flow. The dosing of a batch can be triggered manually and by pulse.

Timer batch

The set batch quantity is dosed with a preset interval.

Slow mode

In slow mode, the pumps slow down the suction stroke. This reduces cavitation when dosing viscous liquids.

Slow mode can be activated in any operating mode.

Normal mode

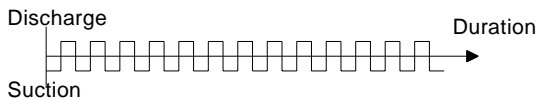

Slow mode

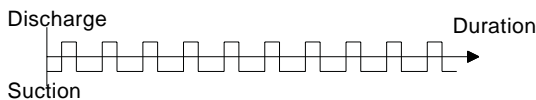

Fig. 7 Slow mode vs. normal operation

Other options

Leak detection

As an option, a system for detecting fluid behind the diaphragm can be installed. In the event of a leak, or diaphragm failure, the controller can trigger an alarm and/or switch off the pump.

Pumps with leak detection have a special dosing head flange for inserting an opto-electronic sensor. The leak detection sensor is installed from factory.

The opto-electronic sensor contains:

- infrared transmitter
- infrared receiver.

Leak-detection opto-sensor

In the event of a leak in the diaphragm:

- liquid penetrates the dosing head flange
- light refraction changes
- the sensor emits a signal.

The electronics switches two contacts, which can be used, for example, to trigger an alarm signal or to switch off the pump.

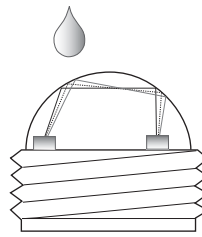

TM03 3628 0506

Fig. 8 Leak-detection opto-sensor

Tank level control

Two-stage empty-tank signal. This requires a separate empty-tank sensor, not included with the pump.

Flow monitor (option)

This unit monitors the dosing process and emits a pulse for each suction stroke. Only for aqueous liquids with a maximum viscosity of 5 mPa s.

Electronic lock

The pump can be locked to prevent it from being stopped manually. When activating this function (service level), the pump starts running with the present settings and cannot be stopped by means of the "Start/Stop" button.

It is still possible to acknowledge error messages by means of the "Start/Stop" button.

To stop the pump when the electronic lock is activated:

- If the 'remote switching' is connected: switch off the pump remotely
- Disconnect the pump from the power supply.

Calibration

The dosing flow display is factory-set to an operating back pressure of 43.5 psi (3 bar). Calibration can be used to set the pump flow to the actual operating conditions.

TM03 4466 2106

Remote on/off

The pump can be switched off remotely (for example from a control room).

- If the pump is switched off remotely, it does not respond to any input signals or to operator inputs. Exception: The pump can still be stopped manually (press the "Start/Stop" button) and run in continuous operation (press and hold down the "Start/Stop" button).

- "Stop" is indicated in the display.
- The yellow LED is on.
- When it is switched on remotely, the pump returns to the state it was in before it was switched off. If, for example, the pump was previously in "Stop" mode, it returns to this mode once it is switched on.

Profibus

The DDI is also available with a Profibus DP interface.

Connectors

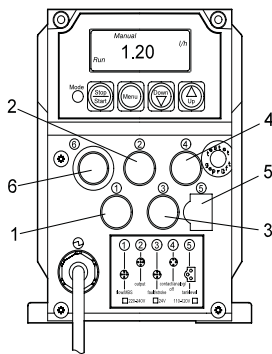

TM03 4452 2106

Fig. 9 Connectors on the DDI 209 AR

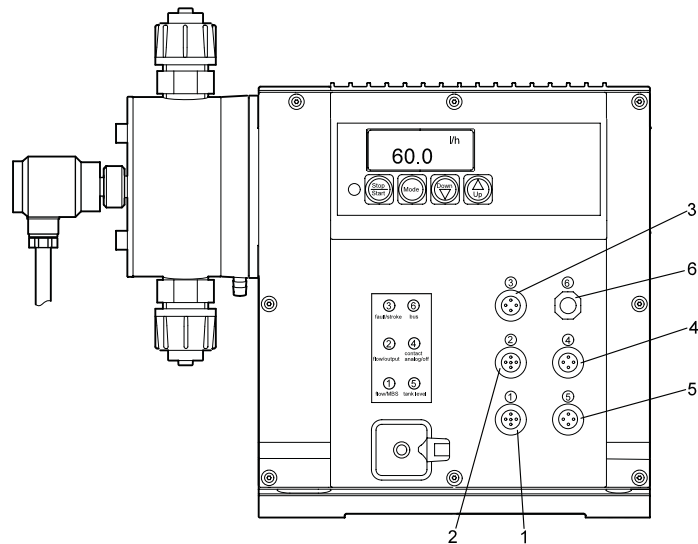

TM03 4780 2806

Fig. 10 Connectors on the DDI 222 AR

Legend

Socket	Description
1	Leakage detection (Flow monitor)
2	Current output (indicates the current dosing flow) Flow monitor
3	Electrically isolated output for stroke/pulse signal or empty-tank pre-alert signal and error signal
4	Remote on/off Contact input Current input
5	Empty-tank signal Empty-tank pre-alert and empty-tank signal
6	Profibus (option) Only used when the Profibus option is selected.

General description

The DDI range of pumps are digitally controlled dosing pumps.

DDI 209

The DDI 209 AR and AM are electronic stepper-motor-driven pumps. The rotation of the motor generates the discharge stroke via an eccentric. The suction stroke is performed by a spring.

The control panel can be top or side-mounted.

DDI 209 AR

DDI 209 AR is available in a range of versions.

The various head types available feature:

- manual vent valve
- Plus³ system (P3)
- leak detection.

As an option, the DDI 209 AR can also be equipped with:

- flow monitor
- interface for Profibus (AP).

DDI 209 AM

The DDI 209 AM is equipped with integrated dosing monitoring and control. The dosing flow is measured continuously and regulated to the specified setpoint independent of the back pressure.

The DDI 209 AM is available in a range of versions.

As an option, it can also be equipped with an interface for Profibus (APM).

DDI 222 AR

The DDI 222 AR is driven by a brushless DC motor, resulting in low energy costs. The speed of the motor is reduced by means of belt drive (toothed belts). On DDI 222 AR the suction and discharge strokes are generated by the motor.

The control panel can be front- or side-mounted.

DDI 209 AR with manual vent valve

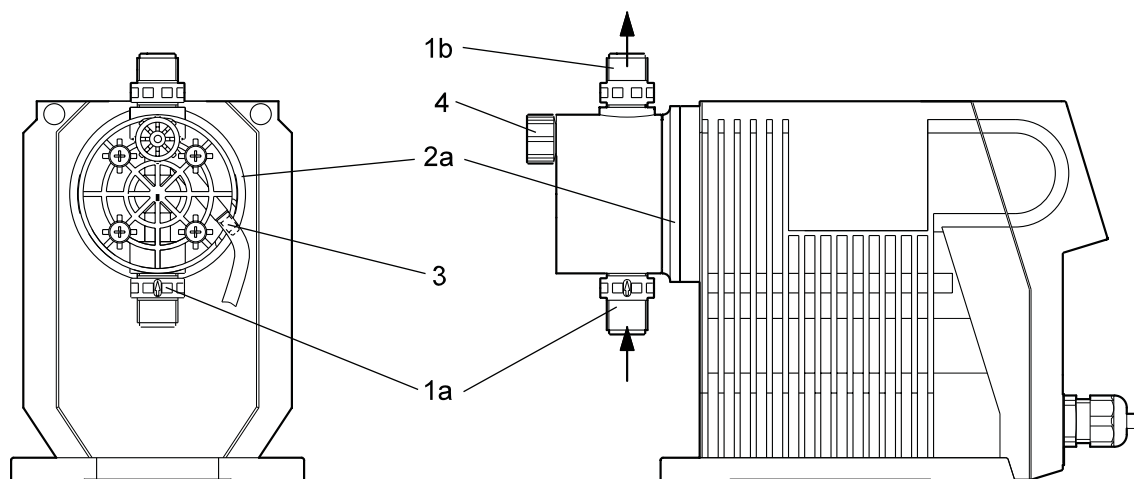

Fig. 1 Main components, DDI 209 AR with manual vent valve

Legend

Pos.	Component
1a	Suction valve
1b	Discharge valve
2a	Dosing head with manual vent valve
3	Connection for vent tubing
4	Screw to open/close the vent valve

TM03 3723 0806

DDI 222 AR

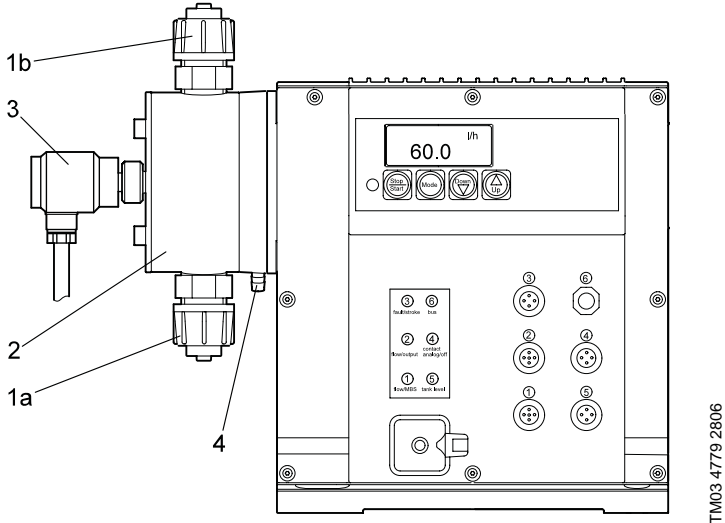

Fig. 2 Main components, DDI 222 AR

Legend

Pos.	Component
1a	Suction valve
1b	Discharge valve
2	Dosing head
3	Leakage detection pressure switch
4	Outlet joint in case of diaphragm breakage

DDI 209 AR with Plus³ system

With auto-venting and calibration system for moderately volatile liquids (such as sodium hypochlorite).

(Only with sizes DDI 0.4-10 to DDI 6-10)

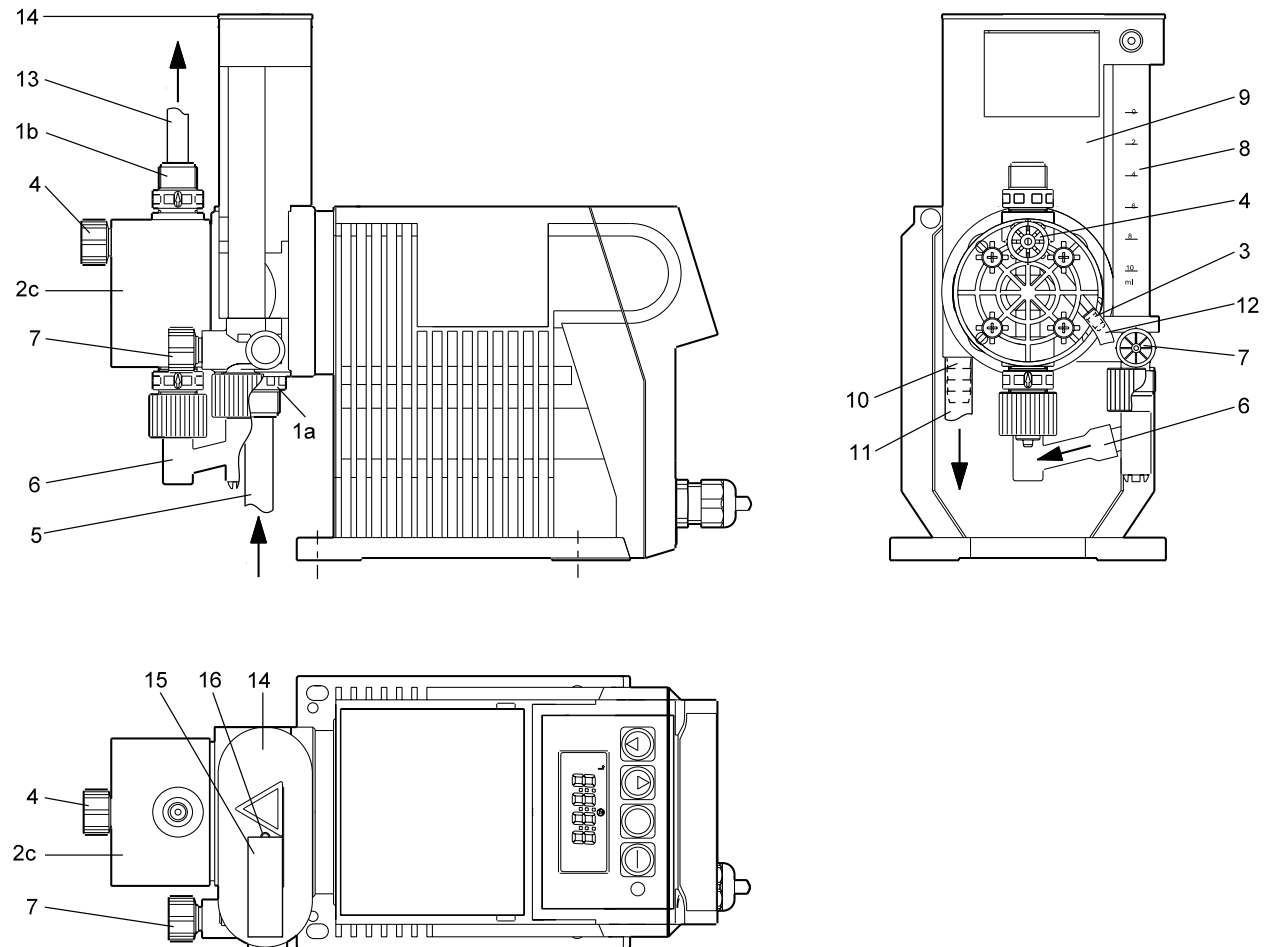

Fig. 3 Main components, DDI 209 AR with Plus³ (P3) system

Legend:

Pos.	Component
1a	Suction valve
1b	Discharge valve
2c	Dosing head Plus ³ system
3	Connection for venting line
4	Air vent screw
5	Suction line from the tank
6	Line from the calibration tube (pos. 8) to the dosing head
7	Isolating valve at the calibration tube (pos. 8)
8	Calibration tube
9	Pre-lifting chamber
10	Connection for overflow line (pos. 11)
11	Overflow line to the tank (PVC tube 8/11)

Pos.	Component
12	Venting line to the tank
13	Dosing line (discharge line)
14	Cover
15	Adhesive label
16	Ventilation hole

TM03 3727 0806

DDI 209 AM

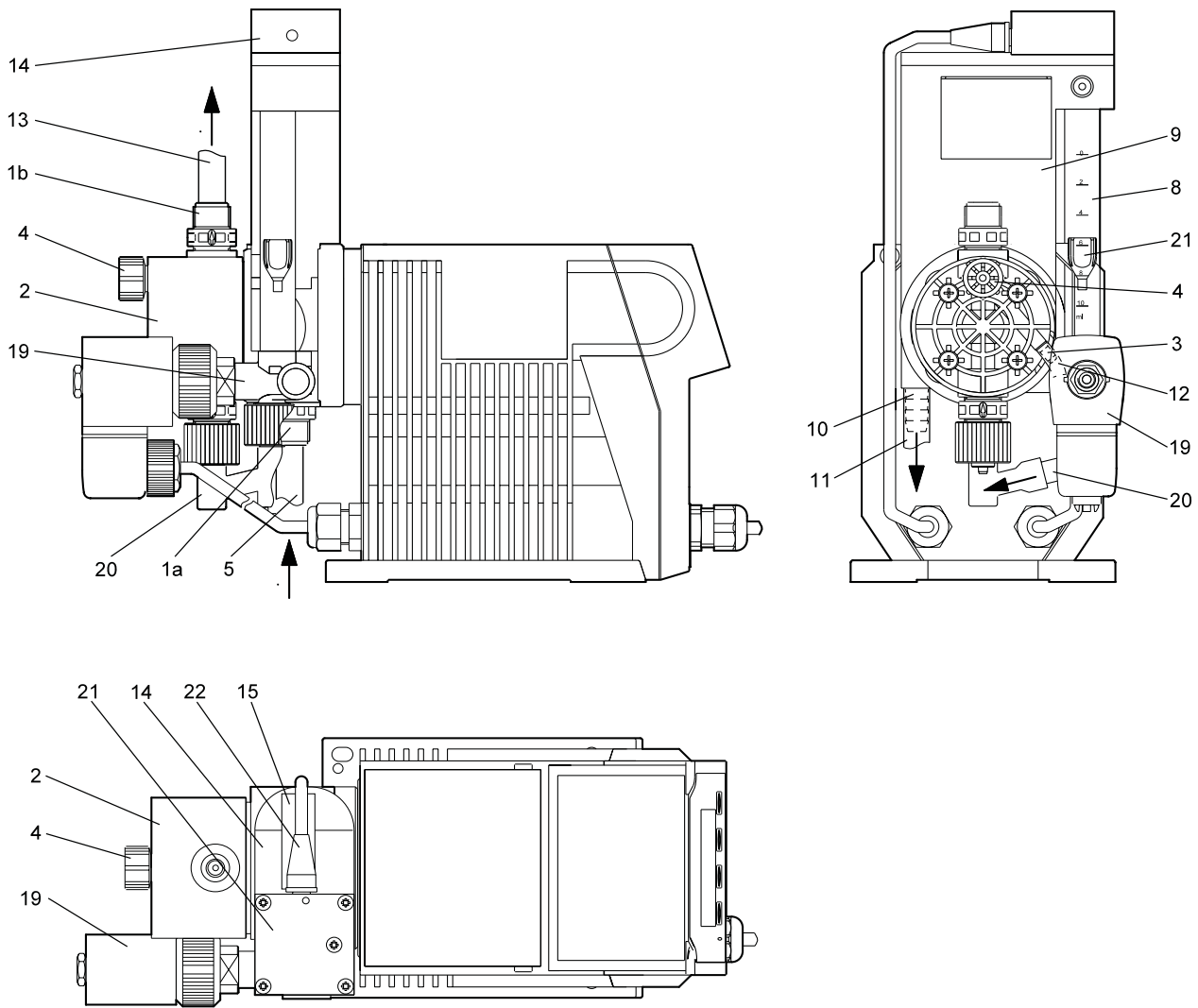

Fig. 4 Main components, DDI 209 AM

Legend

Pos.	Component
1a	Suction valve
1b	Discharge valve
2	Dosing head
3	Connection for venting line
4	Air vent screw
5	Suction line from the tank
8	Calibration tube
9	Pre-lifting chamber
10	Connection for overflow line (pos. 11)
11	Overflow line to the tank (PVC tube 8/11)
12	Venting line to the tank
13	Dosing line (discharge line)

Pos.	Component
14	Cover
15	Adhesive label
19	Solenoid valve on the calibration tube (pos. 8)
20	Line from the calibration tube (pos. 8) to the dosing head
21	Float
22	Ultrasonic sensor

The DDI AM features the Plus³ system. In addition an ultrasonic sensor is used to continuously calibrate for maximum dosing accuracy.

TM03 3729 0806

Functional principle of the Plus³ system

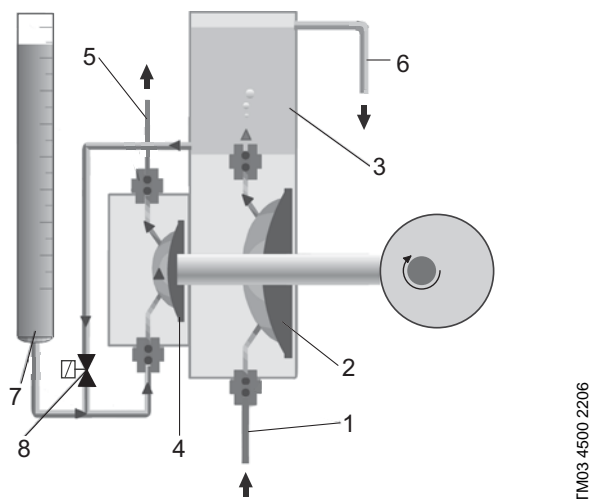

Fig. 5 Functional principle of the Plus³ system

Legend:

Pos.	Component
1	Inlet from tank
2	Conveying diaphragm
3	Priming/deaeration chamber
4	Dosing diaphragm
5	Discharge to the process line
6	Deaeration bypass
7	Calibration tube
8	Calibration valve

Operation of the Plus³ system

- The conveying diaphragm (pos. 2) draws a large volume of liquid from the supply tank (pos. 1) and pumps it into the priming/deaeration chamber (pos. 3).
- Any gas bubbles in the liquid are vented to the atmosphere in the priming chamber.
- The separate, working diaphragm (pos. 4) pumps the liquid into the process line (pos. 5).
- Any excess liquid is returned to the tank via the deaeration bypass (pos. 6).
- The integrated calibration column (pos. 7) and calibration valve (pos. 8) allow precise adjustment of the flow while the pump is running.

Designed especially for volatile chemicals, the double-diaphragm system offers high process accuracy and cost-efficient operation.

As an additional feature of the Plus³ system, the priming chamber allows the pump to be in a suction lift configuration. This permits the exchange of chemical tanks without interrupting the chemical discharge to the system.

Spring-loaded valves

The pump head can be supplied with spring-loaded valves for improved performance when handling viscous liquids. Some of these valves have a larger nominal width and incorporate adapters.

Note: The suction and discharge dimensions of the pump may change when the pump is fitted with spring-loaded valves.

DDI AR with leak detection

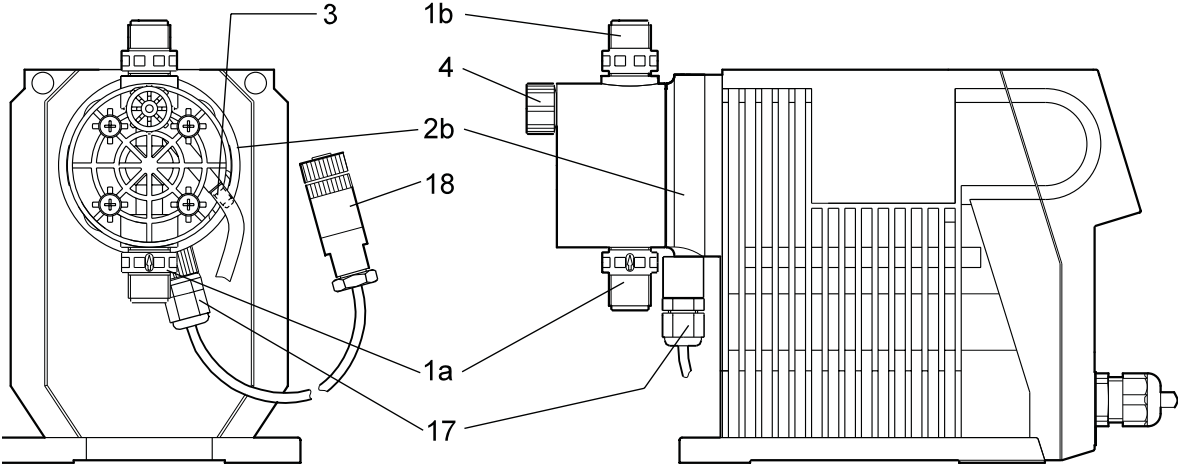

Fig. 6 Main components, DDI 209 AR with leak detection

Legend

Pos.	Component
1a	Suction valve
1b	Discharge valve
2b	Dosing head with flange for diaphragm-breakage signal
3	Connection for venting line
4	Air vent screw for manual venting
17	Opto-sensor
18	M12 plug for socket 1

TM03 3725 0806

Dimensions

DDI 209 AR

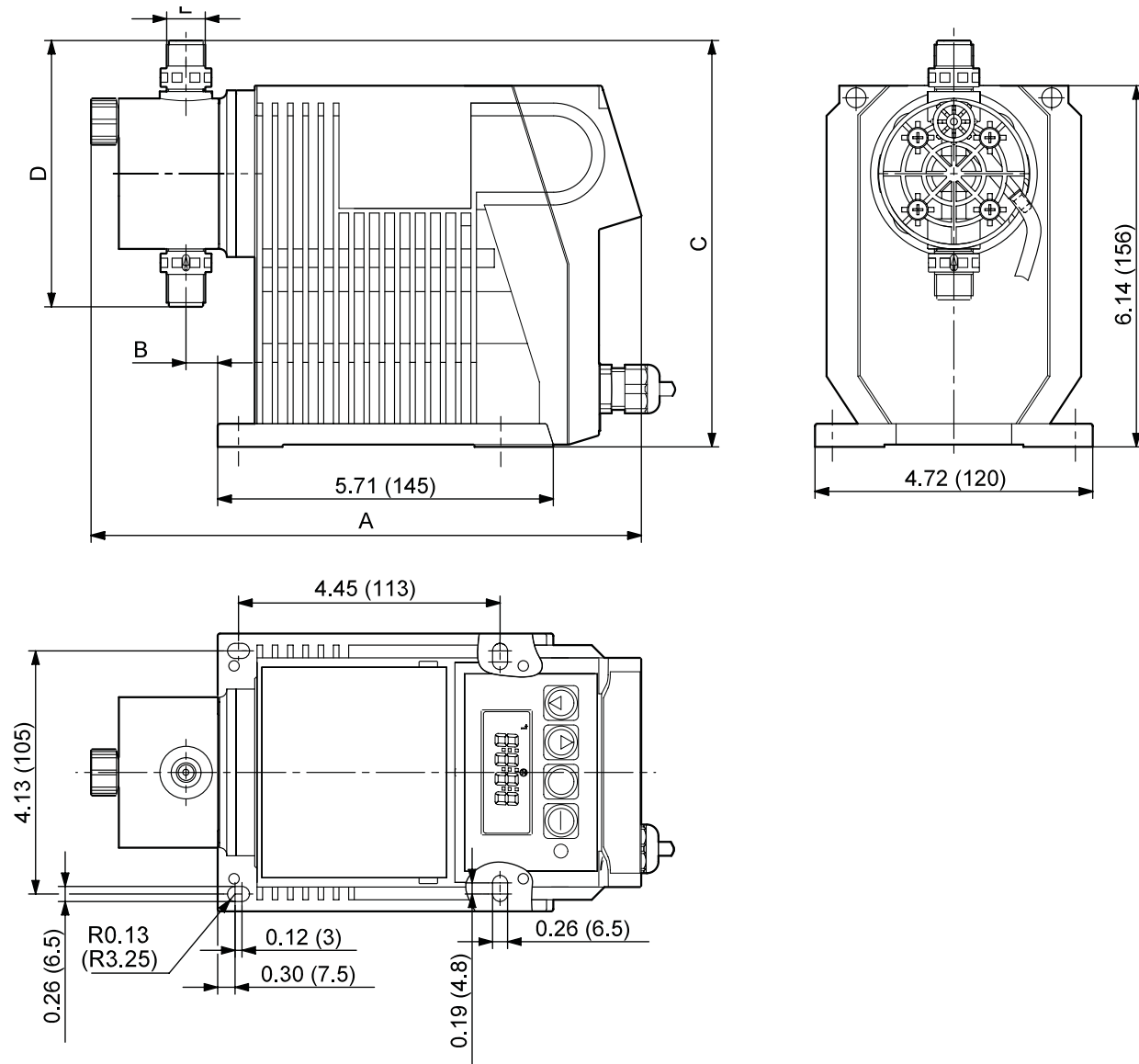

Fig. 1 Dimensions, DDI 209 AR

TM03 4876 3206

Dimensions [inches (mm)]

Pump	Model	A	B	C	D	E	C HV*	D HV*	E HV*
DDI 0.4-10	209 AR	9.41 (239)	0.91 (23)	6.91 (175.5)	4.41 (112)	G 3/8	6.91 (175.5)	4.41 (112)	G 3/8
DDI 2-16	209 AR	9.41 (239)	0.91 (23)	6.91 (175.5)	4.41 (112)	G 3/8	8.17 (207.5)	6.93 (176)	G 5/8
DDI 3-10	209 AR	9.41 (239)	0.91 (23)	6.91 (175.5)	4.41 (112)	G 3/8	8.17 (207.5)	6.93 (176)	G 5/8
DDI 6-10	209 AR	9.41 (239)	0.91 (23)	6.91 (175.5)	4.41 (112)	G 3/8	8.17 (207.5)	6.93 (176)	G 5/8
DDI 14-4	209 AR	9.45 (240)	1.14 (29)	7.28 (185)	5.24 (133)	G 5/8	7.28 (185)	5.24 (133)	G 5/8
DDI 20-3	209 AR	9.45 (240)	1.14 (29)	7.28 (185)	5.24 (133)	G 5/8	7.28 (185)	5.24 (133)	G 5/8

*Adjusted dimensions for high-viscosity option

DDI 209 AR with Plus³ system

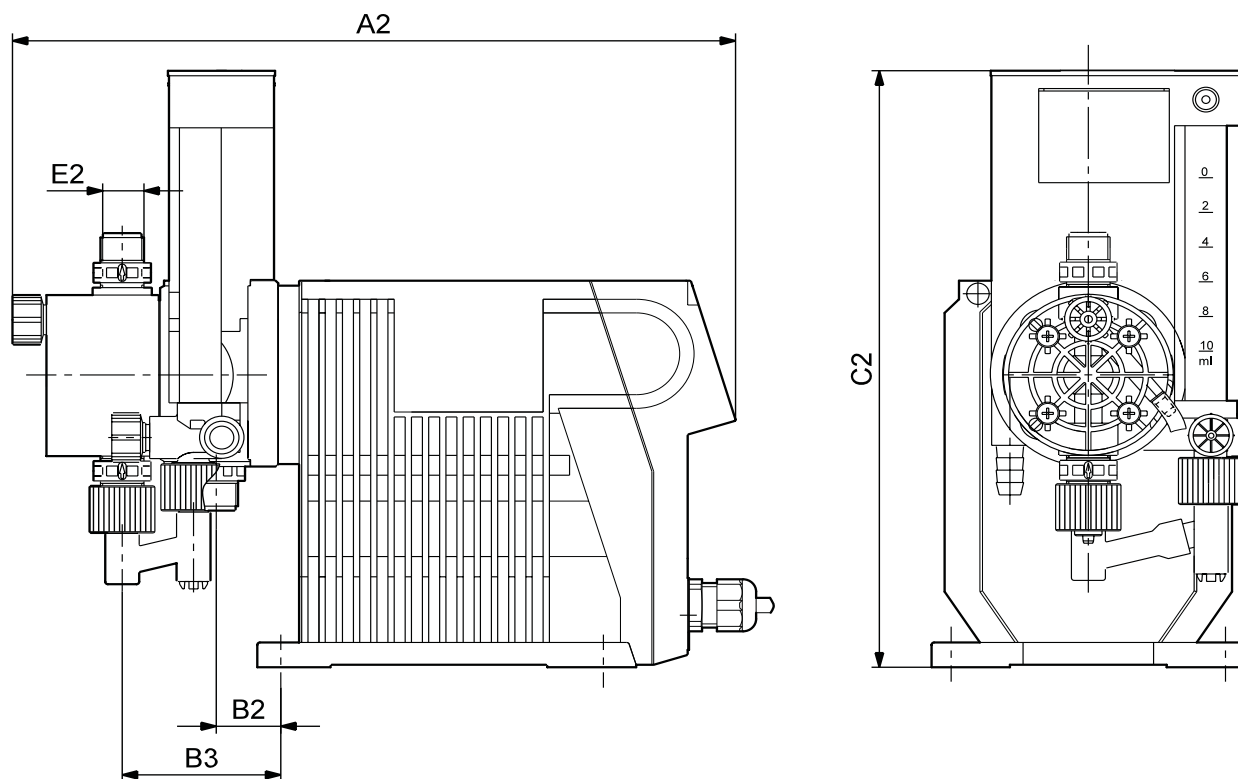

TM03 3726 0806

Fig. 2 DDI 209 AR with Plus³ system

Dimensions [inches (mm)]

Pump	Model	A2	B2	B3	C2	E2
DDI 0.4-10	209 AR	10.87 (276)	0.98 (25)	2.4 (61)	9.45 (240)	G 3/8
DDI 2-16	209 AR	10.87 (276)	0.98 (25)	2.4 (61)	9.45 (240)	G 3/8
DDI 3-10	209 AR	10.87 (276)	0.98 (25)	2.4 (61)	9.45 (240)	G 3/8
DDI 6-10	209 AR	10.87 (276)	0.98 (25)	2.4 (61)	9.45 (240)	G 3/8
DDI 14-4	209 AR	- (-)	- (-)	- (-)	- (-)	-
DDI 20-3	209 AR	- (-)	- (-)	- (-)	- (-)	-

DDI 209 AR with leak detection

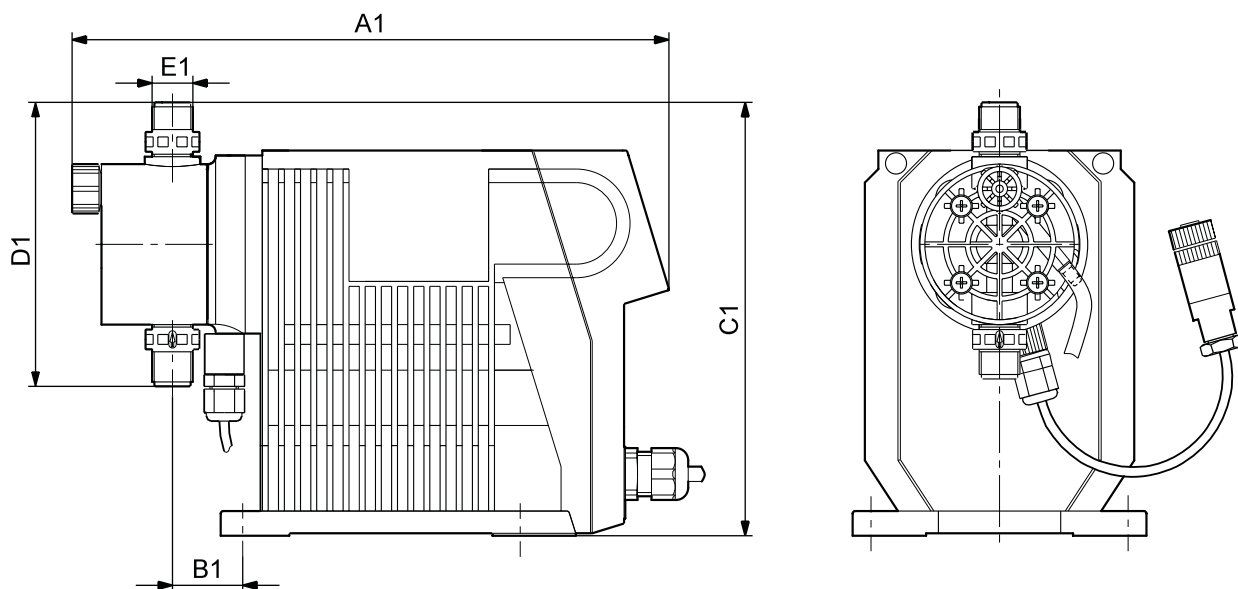

TM03 3724 0806

Fig. 3 DDI 209 AR with leak detection

Dimensions [inches (mm)]

Pump	Model	A1	B1	C1	D1	E1	C1 HV*	D1 HV*	E1 HV*
DDI 0.4-10	209 AR	9.84 (250)	1.34 (34)	6.91 (175.5)	4.41 (112)	G 3/8	6.91 (175.5)	4.41 (112)	G 3/8
DDI 2-16	209 AR	9.84 (250)	1.34 (34)	6.91 (175.5)	4.41 (112)	G 3/8	8.17 (207.5)	6.93 (176)	G 5/8
DDI 3-10	209 AR	9.84 (250)	1.34 (34)	6.91 (175.5)	4.41 (112)	G 3/8	8.17 (207.5)	6.93 (176)	G 5/8
DDI 6-10	209 AR	9.84 (250)	1.34 (34)	6.91 (175.5)	4.41 (112)	G 3/8	8.17 (207.5)	6.93 (176)	G 5/8
DDI 14-4	209 AR	9.88 (251)	1.57 (40)	7.28 (185)	5.24 (133)	G 5/8	7.28 (185)	5.24 (133)	G 5/8
DDI 20-3	209 AR	9.88 (251)	1.57 (40)	7.28 (185)	5.24 (133)	G 5/8	7.28 (185)	5.24 (133)	G 5/8

* Adjusted dimensions for high-viscosity option

DDI 209 AM

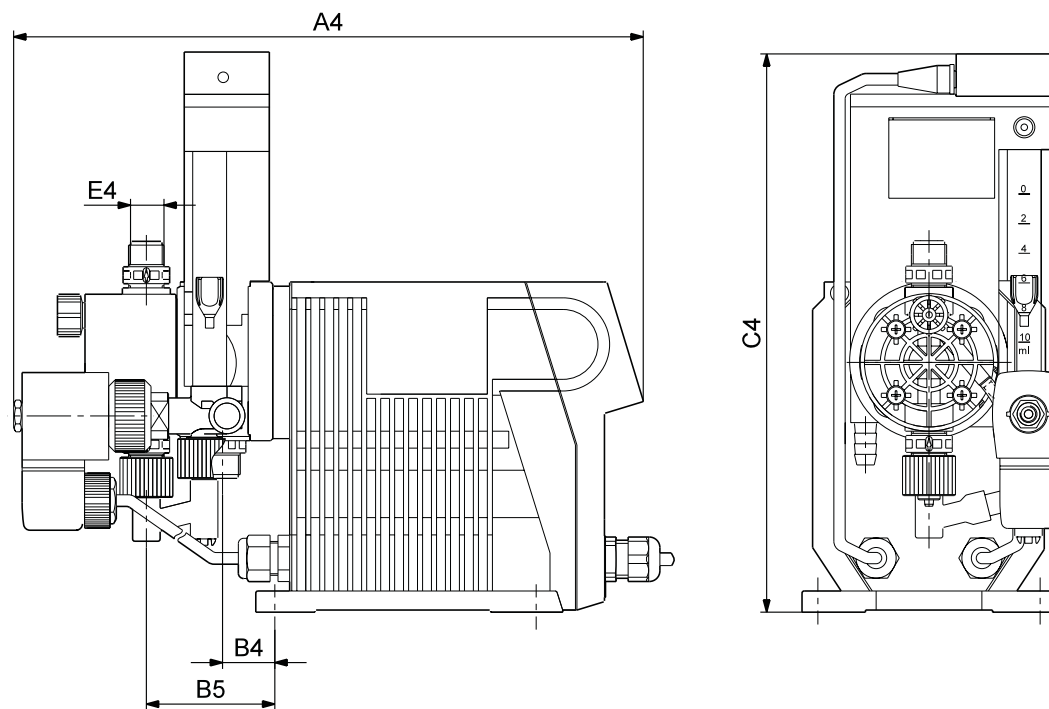

TM03 3728 0806

Fig. 4 Dimensions, DDI 209 AM

Dimensions [inches (mm)]

Pump	Model	A4	B4	B5	C4	E4
DDI 0.4-10	209 AM	11.73 (298)	2.4 (61)	0.98 (25)	10.43 (265)	G 3/8
DDI 2-16	209 AM	11.73 (298)	2.4 (61)	0.98 (25)	10.43 (265)	G 3/8
DDI 3-10	209 AM	11.73 (298)	2.4 (61)	0.98 (25)	10.43 (265)	G 3/8
DDI 6-10	209 AM	11.73 (298)	2.4 (61)	0.98 (25)	10.43 (265)	G 3/8

DDI 222 AR

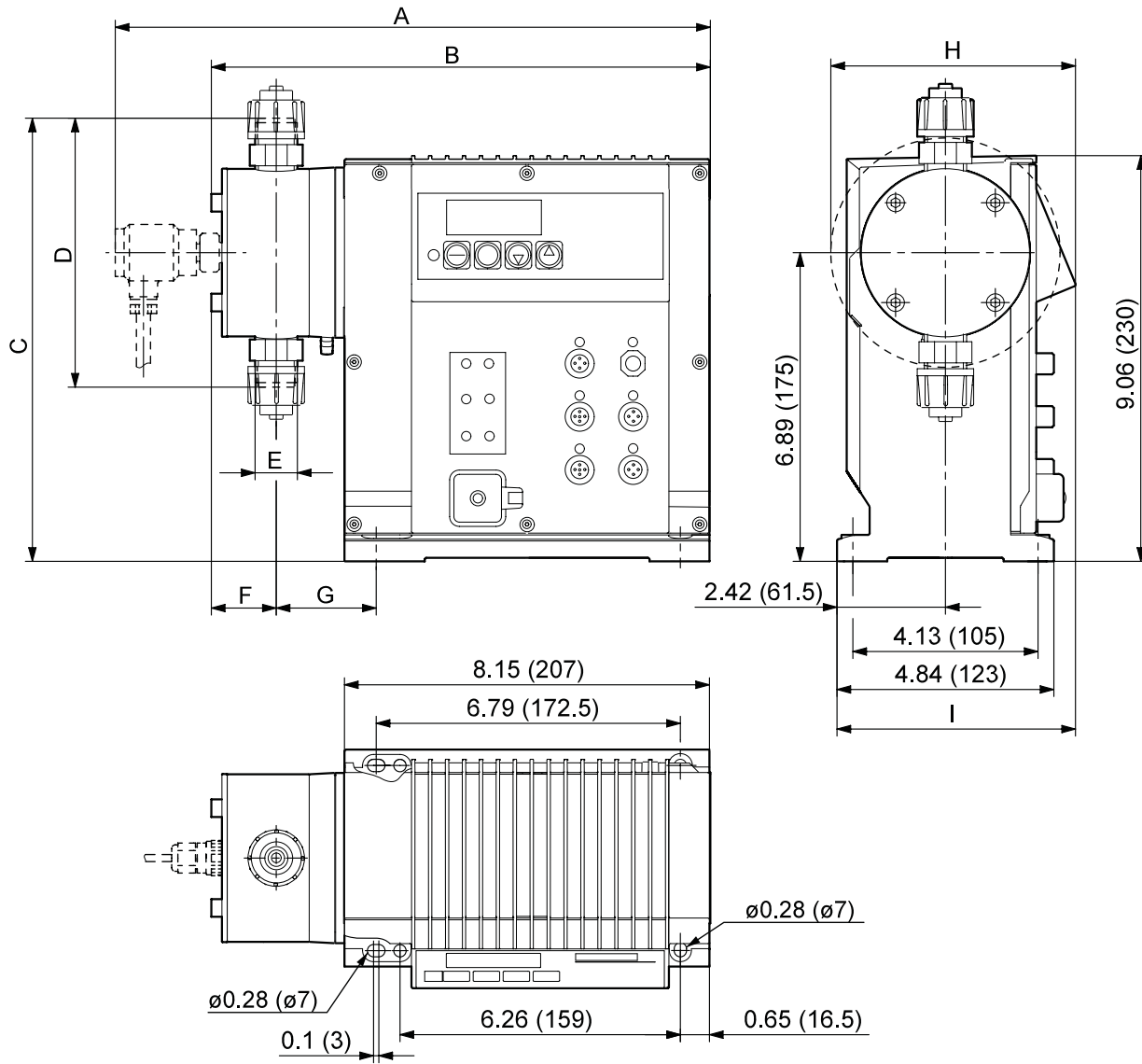

TM03 4877 3206

Dimensions [inches (mm)]

Pump	Model	A	B	C	D	E	F	G	H	I	CHV*	DHV*	EHV*	FHV*	GHV*
DDI 60-10	222 AR	12.83 (326)	10.71 (272)	9.92 (252)	6.02 (153)	R 5/8	1.02 (26)	2.28 (58)	- (-)	5.39 (137)	9.69 (246)	5.63 (143)	R 1 1/4	1.54 (39)	3.54 (90)
DDI 150-4	222 AR	14.65 (372)	12.4 (315)	10.43 (265)	7.05 (179)	R 1 1/4	1.54 (39)	3.54 (90)	5.47 (139)	5.39 (137)	10.43 (265)	7.05 (179)	R 1 1/4	1.54 (39)	3.54 (90)

* Adjusted dimensions for high-viscosity option

Performance data

DDI 209 AR

Pump	Model	Vstroke [cm ³]	Max. pressure ¹⁾ [psi, (bar)]	Normal operation		Slow mode		Max. stroke rate [strokes/min]
				Capacity ²⁾ [GPH, (l/h)]	Capacity ²⁾ Plus ³ system [GPH, (l/h)]	Capacity ²⁾ [GPH, (l/h)]	Capacity ²⁾ Plus ³ system [GPH, (l/h)]	
DDI 0.4-10	209 AR	0.069	145 (10)	0.11* (0.4*)	0.105* (0.4*)	0.071 (0.26)	0.071 (0.27)	180
DDI 2-16	209 AR	0.276	232 (16)	0.58 (2.2)	0.5 (1.9)	0.39 (1.5)	0.32 (1.3)	180
DDI 3-10	209 AR	0.276	145 (10)	0.66 (2.5)	0.58 (2.2)	0.45 (1.7)	0.37 (1.4)	180
DDI 6-10	209 AR	0.587	145 (10)	1.45 (5.5)	1.29 (4.9)	0.97 (3.7)	0.84 (3.2)	180
DDI 14-4	209 AR	1.36	58 (4)	3.64 (13.8)	- (-)	2.38 (9.2)	- (-)	180
DDI 20-3	209 AR	1.95	43.5 (3)	5.28 (20)	- (-)	3.43 (13.3)	- (-)	180

1) Please observe the maximum permissible temperatures. When dosing the more viscous liquids, observe the maximum permissible viscosity.

2) The maximum dosing flow of HV type pumps is reduced by up to 10%.

* At counter pressures lower than 145 psi, the maximum dosing flow of the DDI 0.4-10 gradually increases to a maximum of 0.26 GPH.

The maximum capacity is measured at maximum pump back pressure.

The pump can be operated in the range of 1% to 100% of the maximum dosing capacity,

DDI 209 AM

Pump	Model	Vstroke [cm ³]	Max. pressure ¹⁾ [psi, (bar)]	Normal operation	Slow mode	Max. stroke rate [strokes/min]
				Capacity ²⁾ [GPH, (l/h)]	Capacity ²⁾ [GPH, (l/h)]	
DDI 0.4-10	209 AM	0.069	145 (10)	0.105* (0.4*)	0.071 (0.27)	180
DDI 2-16	209 AM	0.276	232 (16)	0.5 (1.9)	0.32 (1.2)	180
DDI 3-10	209 AM	0.276	145 (10)	0.58 (2.2)	0.37 (1.4)	180
DDI 6-10	209 AM	0.587	145 (10)	1.29 (4.9)	0.84 (3.2)	180

1) Observe the maximum permissible temperatures. When dosing the more viscous liquids, observe the maximum permissible viscosity.

2) The maximum dosing flow of HV type pumps is reduced by up to 10%.

* At counter pressures lower than 145 psi, the maximum dosing flow of the DDI 0.4-10 gradually increases to a maximum of 0.26 GPH.

The maximum capacity is measured at maximum pump back pressure.

The pump can be operated in the range 1% to 100% of the maximum dosing capacity,

DDI 222 AR

Pump	Model	Vstroke [cm ³]	Max. pressure ¹⁾ [psi (bar)]	Capacity ²⁾ [GPH (l/h)]			Max. stroke rate [strokes/min]
				Normal	Slow mode-1	Slow mode-2	
DDI 60-10	222 AR	6.63	145 (10)	15.9 (60)	10.6 (40)	6.5 (24.7)	180
DDI 150-4	222 AR	13.9	58 (4)	39.7 (150)	26.4 (100)	16.4 (62)	180

1) Observe the maximum permissible temperatures. When dosing the more viscous liquids, observe the maximum permissible viscosity.

2) The maximum dosing flow of HV type pumps is reduced by up to 10%.

The maximum capacity is measured at maximum pump back pressure.

The pump can be operated in the range of 0.125% to 100% of the maximum dosing capacity,

Suction lift

DDI 209 AR

Pump	Model	Max. suction lift during operation ¹⁾ Viscosity similar to water [ft (m)]				Max. suction lift Start-up ²⁾ Non-degassing liquids Viscosity similar to water [ft (m)]	
		Normal	Slow mode	Normal with Plus ³	Slow mode with Plus ³	Standard	Plus ³
DDI 0.4-10	209 AR	* (*)	* (*)	4.9 (1.5)	4.9 (1.5)	* (*)	** (**)
DDI 2-16	209 AR	13.1 (4)	19.7 (6)	4.9 (1.5)	4.9 (1.5)	4.9 (1.5)	** (**)
DDI 3-10	209 AR	13.1 (4)	19.7 (6)	4.9 (1.5)	4.9 (1.5)	4.9 (1.5)	** (**)
DDI 6-10	209 AR	13.1 (4)	19.7 (6)	4.9 (1.5)	4.9 (1.5)	6.6 (2)	** (**)
DDI 14-4	209 AR	9.8 (3)	9.8 (3)	- (-)	- (-)	9.2 (2.8)	- (-)
DDI 20-3	209 AR	9.8 (3)	9.8 (3)	- (-)	- (-)	9.2 (2.8)	- (-)

1) Dosing head and valves moistened.

2) Venting valve open.

* Flooded suction.

** Pumps incorporating the Plus³ system include a special start-up device; consequently, the max. suction lift at start-up is not a problem.

DDI 209 AM

Pump	Model	Max. suction lift during operation ¹⁾ Viscosity similar to water [ft (m)]	
		Normal	Slow mode
DDI 0.4-10	209 AM	4.9 (1.5)	4.9 (1.5)
DDI 2-16	209 AM	4.9 (1.5)	4.9 (1.5)
DDI 3-10	209 AM	4.9 (1.5)	4.9 (1.5)
DDI 6-10	209 AM	4.9 (1.5)	4.9 (1.5)

1) Dosing head and valves moistened.

DDI 222 AR

Pump	Model	Max. suction lift during operation ¹⁾ Viscosity similar to water [ft (m)]	Max. suction lift Start-up ²⁾ Non-degassing liquids Viscosity similar to water [ft (m)]
		Normal operation	Standard
DDI 60-10	222 AR	9.8 (3)	3.3 (1)
DDI 150-4	222 AR	6.6 (2)	3.3 (1)

1) Dosing head and valves moistened.

2) Venting valve open.

Permissible viscosity

DDI 209 AR

Pump	Model	Max. permissible viscosity at operating temperature ¹⁾ [cps]				Max. permissible viscosity at operating temperature ¹⁾ Spring-loaded valves ²⁾ [cps]			
		Normal operation	Slow-mode operation	Normal operation Plus ³ system	Slow-mode operation Plus ³ system	Normal operation	Slow-mode operation	Normal operation Plus ³ system	Slow-mode operation Plus ³ system
		DDI 0.4-10	209 AR	200	200	200	200	500	500
DDI 2-16	209 AR	200	200	200	200	500	1000	-	-
DDI 3-10	209 AR	200	200	200	200	200	500	-	-
DDI 6-10	209 AR	100	200	100	200	200	500	-	-
DDI 14-4	209 AR	100	200	-	-	200	500	-	-
DDI 20-3	209 AR	100	200	-	-	200	500	-	-

1) The specified values are approximate values and refer to Newtonian liquids.

2) Version for high-viscosity liquids.

Please note the increasing viscosity at lower temperatures.

DDI 209 AM

Pump	Model	Max. permissible viscosity at operating temperature ¹⁾ [cps]		Max. permissible viscosity at operating temperature ¹⁾ Spring-loaded valves ²⁾ [cps]	
		Normal operation	Slow mode operation	Normal operation	Slow mode operation
		DDI 0.4-10	209 AM	50	100
DDI 2-16	209 AM	50	100	-	-
DDI 3-10	209 AM	50	100	-	-
DDI 6-10	209 AM	25	50	-	-

1) The specified values are approximate values and refer to Newtonian liquids.

2) Version for high-viscosity liquids.

Please note the increasing viscosity at lower temperatures.

DDI 222 AR

Pump	Model	Max. permissible viscosity at operating temperature ¹⁾ [cps]			Max. permissible viscosity at operating temperature ¹⁾ Spring-loaded valves ²⁾ [cps]		
		Normal operation	Slow mode-1 operation	Slow mode-2 operation	Normal operation	Slow mode-1 operation	Slow mode-2 operation
		DDI 60-10	222 AR	100	200	500	200
DDI 150-4	222 AR	100	200	500	500	800	2000

1) The specified values are approximate values and refer to Newtonian liquids.

2) Version for high-viscosity liquids.

Please note the increasing viscosity at lower temperatures.

Inlet and discharge pressures

DDI 209 AR

Pump	Model	Max. inlet pressure [psi (bar)]		Min. back pressure [psi (bar)]	
		Standard	Plus ³ system	Standard	Plus ³ system
DDI 0.4-10	209 AR	29 (2)	0* (0*)	14.5 (1)	14.5 (1)
DDI 2-16	209 AR	29 (2)	0* (0*)	14.5 (1)	14.5 (1)
DDI 3-10	209 AR	29 (2)	0* (0*)	14.5 (1)	14.5 (1)
DDI 6-10	209 AR	29 (2)	0* (0*)	14.5 (1)	14.5 (1)
DDI 14-4	209 AR	29 (2)	- (-)	14.5 (1)	14.5 (1)
DDI 20-3	209 AR	21.8 (1.5)	- (-)	14.5 (1)	14.5 (1)

* The pump should be installed without inlet pressure.

DDI 209 AM

Pump	Model	Max. inlet pressure [psi (bar)]	Min. back pressure [psi (bar)]
DDI 0.4-10	209 AM	0* (0*)	14.5 (1)
DDI 2-16	209 AM	0* (0*)	14.5 (1)
DDI 3-10	209 AM	0* (0*)	14.5 (1)
DDI 6-10	209 AM	0* (0*)	14.5 (1)

* The pump should be installed without inlet pressure.

DDI 222 AR

Pump	Model	Max. inlet pressure [psi (bar)]			Min. back pressure [psi (bar)]		
		Normal operation	Slow mode-1 operation	Slow mode-2 operation	Normal operation	Slow mode-1 operation	Slow mode-2 operation
DDI 60-10	222 AR	29 (2)	29 (2)	29 (2)	14.5 (1)	14.5 (1)	14.5 (1)
DDI 150-4	222 AR	29 (2)	29 (2)	29 (2)	14.5 (1)	14.5 (1)	14.5 (1)

Permissible temperature range of the pumped media

Note: The pumped liquid must be fluid. Exceeding the permissible temperatures may cause malfunction or damage to the pump.

Dosing head material	Permissible liquid temperature [°F (°C)]	
	p < 145 psi (10 bar)	p < 232 psi (16 bar)
PVC, PP	32 to 104 (0 to 40)	32 to 68 (0 to 20)
316TiSS *	14 to 158 (-10 to 70)	14 to 158 (-10 to 70)
PVDF**	14 to 140 (-10 to 60)	14 to 68 (-10 to 20)

* Short-term (15 min.) resistance to 248°F at up to 29 psi back pressure.

** Increased resistance to 158°F if back pressure is less than 43 psi.

Weights

Pump	Weights [lbs]	
	PVC, PVDF and Polypropylene	Stainless steel
DDI 0.4-10	5.1 - 6.6	7.7
DDI 2-16	5.1 - 6.6	7.7
DDI 3-10	5.1 - 6.6	7.7
DDI 6-10	5.3 - 6.8	7.9
DDI 14-4	5.7	7.9
DDI 20-3	5.7	7.9
DDI 60-10	11.0	15.4
DDI 150-4	14.3	26.5

Electrical data

	DDI 209	DDI 222
Power supply	100-240 V, 50/60 Hz; 24V DC optional	100-240 V, 50/60 Hz
Power consumption	20 VA	50 VA
Input signal		
pulse signal • min. pulse length: 10 ms • min. pause time: 25 ms)	load < 12 V, 5 mA	load < 12 V, 5 mA
remote on/off	load < 12 V, 5 mA	load < 12 V, 5 mA
empty-tank signal	load < 12 V, 5 mA	load < 12 V, 5 mA
current signal	load < 22 Ohm	load < 22 Ohm
Output signal		
current signal 0(4) - 20 mA	load < 350 Ohm	load < 350 Ohm
error signal	ohmic load < 50 V DC/75 V AC, 0.5 A	ohmic load < 50 V DC/75 V AC, 0.5 A
empty-tank pre-alert	ohmic load < 50 V DC/75 V AC, 0.5 A	ohmic load < 50 V DC/75 V AC, 0.5 A
stroke signal • contact time 200 ms /stroke	ohmic load < 50 V DC/75 V AC, 0.5 A	ohmic load < 50 V DC/75 V AC, 0.5 A
Enclosure class	IP 65	IP 65

Additional technical data

	DDI 209	DDI 222
Control range	1% to 100% of the maximum dosing capacity	0.125% to 100% of the maximum dosing capacity
Accuracy	+/- 1.5% repeatability throughout adjustable range	+/- 1.5% repeatability throughout adjustable range
Permissible ambient temperature	32 to 104 F	32 to 104 F
Permissible storage temperature	14 to 122 F	14 to 122 F
Max. relative humidity	92% (non-condensing)	92% (non-condensing)
Sound pressure level	55 dB (A)	65 ± 5 dB (A)
Material of enclosure (pump and electronics)	s PS FR GF 22 (glass-fibre-reinforced polystyrene)	PPE-SB (fibre-reinforced Luranyl®) Option: Flameproof enclosure
Approvals	CE	CE

Electronic functions

Function	DDI 209 AR	DDI 209 AM	DDI 222 AR
Continuous operation (for functional test, self-priming and dosing head deaeration)	●	●	●
Memory function saves up to 65,000 pulses	●	●	●
Two-stage, empty-tank signal (requires empty-tank sensors)	●	●	●
Integrated, two-step tank level indicator for the dosing system		●	
Flow monitor (option) ¹⁾	●		●
Diaphragm leakage detection (option) ²⁾	●		●
Stroke signal (standard) or empty-tank pre-alert or pulse input (adjustable) ³⁾	●	●	●
Password protection of settings	●	●	●
Calibration function	●		●
Dosing quantity counter with reset to 0	●	●	●
Tamper-proof operating hours counter	●	●	●
Remote on/off	●	●	●
Profibus DP interface (option)	●	●	●
Integrated flow measurement and monitoring		●	
Hall sensor (for motor monitoring) ⁴⁾	●	●	
Pressure limitation ⁵⁾			●

1) The flow monitor for dosing control consists of a pressure sensor integrated in the dosing head. Based on the pressure measured by the sensor and on the motor position, an indicator diagram is created. Possible dosing faults or the exceeding of the admissible back pressure are detected reliably and indicated by the display or the error message output.

2) The dosing head of pumps with diaphragm leakage detection are equipped with opto-electronic sensor.

3) Depending on the relay setting, the contact output receives a signal on:

- each complete stroke of the pump or
- an empty-tank pre-alert signal input or
- each pulse input at the pump.

4) If the pump has existing strokes to process, the Hall sensor checks whether the drive is turning. If the drive motor is blocked, for example due to excess counter pressure in the dosing system, the failure is detected and indicated by the integrated motor monitoring function.

5) The DDI 222, is equipped with integrated pressure control function. The pressure is calculated from the motor current consumption or is measured directly in the dosing head if a pressure sensor is present (flow monitor pump option). At a user-defined pressure, the pump is switched off automatically.

Operating modes, additional data

Operating mode				
Manual control	Input/display of the dosing flow in l/h or gal/h.			
Pulse control (most constant dosing)	Input/display in ml/contact	Pump	V_{max} [ml]	V_{min} [ml]
		DDI 0.4-10	0.001	0.07
		DDI 2-16	0.004	0.88
		DDI 3-10	0.004	0.88
		DDI 6-10	0.011	2.20
		DDI 14-4	0.024	4.96
		DDI 20-3	0.038	7.86
		DDI 60-10	0.111	2.22
		DDI 150-4	0.278	55.5
Analog control	Adjust the volumetric flow in proportion to the current signal (displayed in l/h) Weighting of current input/output			
Batch mode	Input dosing capacity and dosing flow per batch Triggered manually or by contact			
Time batch	Input dosing capacity and dosing flow per batch Input start time for first batch Input repeat time for subsequent batches			
Slow mode	Long suction stroke (for viscous media) (The DDI 222, has a two-stage reduction of the maximum dosing flow to 66% (slow mode 1) or 41% (slow mode 2))			

DDI selection (0.106 to 39.6 GPH)

The example in bold is a **DDI 2-16 AR PVC/V/G-F-313B1 B**

Size	Control variant	Materials of dosing head, gaskets and valve balls	Control panel position	Supply voltage	Valve type	Connection, suction/discharge	Mains plug
0.4-10 2-16 3-10 6-10 14-4 20-3 60-10 150-4	AR = Standard	Dosing head version: PP = Polypropylene	Control panel position F = Front-mounted (variants A, AR)	Supply voltage 3 = 1 x 100-240 V, 50/60 Hz I = 24 VDC	Valve type 1 = Standard 2 = Spring-loaded, 0.7 psi opening pressure, suction/discharge 3 = Spring-loaded, 0.7 psi opening pressure, suction 4 = Spring-loaded, 11.6 psi opening pressure, discharge 5 = For abrasive media (SS only) 6 = Spring-loaded, (DN 20, SS balls) 11.6 psi, discharge side	Connection, suction/discharge B6 = Pipe 4/6 mm 3 = Tube 4/6 mm A5 = Tube 5/8 mm 4 = Tube 6/9 mm 6 = Tube 9/12 mm Q = Tube 19/27 mm C4 = Tube 1/8" / 1/4" R = Tube 1/4" / 3/8" S = Tube 3/8" / 1/2" A = Threaded Rp 1/4" A1 = Threaded Rp 3/4" V = Threaded NPT 1/4" A9 = Threaded NPT 1/2", male A3 = Threaded NPT 3/4" A7 = Threaded NPT 3/4", male B1 = Tube 6/12 mm/cementing d. 12 mm B2 = Tube 13/20 mm/cementing d. 25 mm B2 = Welding d. 16 mm B4 = Welding d. 25 mm	Mains plug B = USA and Canada, 120 V
	AM= AR with Plus ³ and continuous calibration	PV = PVDF PVC= Polyvinyl chloride SS = Stainless steel, AISI 316 PP-P3	T = Top-mounted (variants A, AR)				
	AF = AR with flow monitor	= PP + Plus ³ system PVC-P3					
	AP = AR with Profibus	= PVC + Plus ³ system PP-L= PP + integrated diaphragm leakage detection					
	APM= AM with Profibus	PV-L= PV + integrated diaphragm leakage detection					
	APF= AR with flow monitor and Profibus	PVC-L = PVC + integrated diaphragm leakage detection SS-L= SS + integrated diaphragm leakage detection					
	Gasket material: E = EPDM V = FKM T = PTFE						
	Valve ball material: C = Ceramic G = Glass T = PFFE SS = Stainless steel, AISI 316						

Size	Control variant	Materials of dosing head, gaskets and valve balls	Control panel position	Supply voltage	Valve type	Connection, suction/discharge	Mains plug
DDI 209 AR							
0.4-10 2-16 3-10 6-10 14-4 20-3	AR AF AP APF	PP/E/C	F T	3 I	1 2 3 4	3	B
		PP/V/G				4	
		PV/T/C (not with 2-16)				A	
		PVC/E/G				R	
		SS/T/SS	F T	3 I	1 2 3 4	A5	B
		SS/V/SS				A9	
						B1	
						B3	
						B6	
						C4	

DDI 209 AR with Plus³							
0.4-10 2-16 3-10 6-10	AR AF AP APF	PP-P3/E/C	F T	3 I	1 2 3 4	3	B
		PP-P3/V/C				4	
		PVC-P3/E/C				A	
		PVC-P3/V/C				S	
			F T	3 I	1 2 3 4	V	B
						A5	
						A9	
						B1	
						B3	
						B6	

Pump selection

DDI

Size	Control variant	Materials of dosing head, gaskets and valve balls	Control panel position	Supply voltage	Valve type	Connection, suction/discharge	Mains plug
0.4-10 2-16 3-10 6-10 14-4 20-3 60-10 150-4	AR = Standard	Dosing head version: PP = Polypropylene	Control panel position F = Front-mounted (variants A, AR)	Supply voltage 3 = 1 x 100-240 V, 50/60 Hz I = 24 VDC	Valve type 1 = Standard 2 = Spring-loaded, 0.7 psi opening pressure, suction/discharge 3 = Spring-loaded, 0.7 psi opening pressure, suction 11.6 psi opening pressure, discharge 4 = Spring-loaded, 11.6 psi opening pressure, discharge 5 = For abrasive media (SS only) 6 = Spring-loaded, (DN 20, SS balls) 11.6 psi, discharge side	Connection, suction/discharge B6 = Pipe 4/6 mm 3 = Tube 4/6 mm A5 = Tube 5/8 mm 4 = Tube 6/9 mm 6 = Tube 9/12 mm Q = Tube 19/27 mm C4 = Tube 1/8" / 1/4" R = Tube 1/4" / 3/8" S = Tube 3/8" / 1/2" A = Threaded Rp 1/4" A1 = Threaded Rp 3/4" V = Threaded NPT 1/4" A9 = Threaded NPT 1/2", male A3 = Threaded NPT 3/4" A7 = Threaded NPT 3/4", male B1 = Tube 6/12 mm/cementing d. 12 mm B2 = Tube 13/20 mm/cementing d. 25 mm B2 = Welding d. 16 mm B4 = Welding d. 25 mm	Mains plug B = USA and Canada, 120 V
	AM= AR with Plus ³ and continuous calibration	PV = PVDF PVC= Polyvinyl chloride SS = Stainless steel, AISI 316	T = Top-mounted (variants A, AR)				
	AF = AR with flow monitor	= PP + Plus ³ system PVC-P3					
	AP = AR with Profibus	= PVC + Plus ³ system PP-L= PP + integrated diaphragm leakage detection					
	APM= AM with Profibus	PV-L= PV + integrated diaphragm leakage detection					
	APF= AR with flow monitor and Profibus	PVC-L = PVC + integrated diaphragm leakage detection SS-L= SS + integrated diaphragm leakage detection					
		Gasket material: E = EPDM V = FKM T = PTFE					
		Valve ball material: C = Ceramic G = Glass T = PFFE SS = Stainless steel, AISI 316					
DDI 222 AR							
60-10 150-4	AR	PV/T/T	F	3	1	4	B
	AF	PVC/E/SS	S	I	2	6	
150-4	AP	PVC/T/T (only with 60-10)			5	A1	B
	APF	PVC/V/G (only with 150-4)			6	A3 A9 B1 B2 B3 B4	
					1		
		SS/V/SS	F	3	2	A9	B
			S	I	5	V	
					6		
DDI 209 AM							
0.4-10 2-16 3-10 6-10	AM	PP/E/C	F	3	1	3	B
	APM	PP/V/C	T	I	2	4	
		PVC/E/C			3	A	
		PVC/V/C			4	S V A5 A9 B1 B3 B6	

List of pumped liquids

The table below is intended only as a general guide on the resistance of materials (at room temperature) to the liquids listed. The table cannot replace actual testing of the pumped liquids and pump materials under specific working conditions.

The list should, however, be applied with some caution as factors such as purity, temperature, abrasive particles, etc. may affect the chemical resistance of a specific material.

Note: Some of the liquids in this table may be toxic, corrosive or hazardous. Be careful when handling the liquids.

Pumped liquid (68°F)			Materials									
Designation	Chemical formula	Concentration %	Pump housing				Gasket				Ball	
			PP	PVDF	Stainless steel, 316	PVC	FKM (e.g. Viton®)	EPDM	PTFE (e.g. Teflon®)	Centellen C	Ceramic	Glass
Acetic acid	CH ₃ COOH	25	●	●	●	●	●	●	●	●	●	●
		60	●	●	●	●	○	●	○	●	●	
		85	●	●	●	○	○	●	○	●	●	
Aluminium chloride	AlCl ₃	40	●	●	○	●	●	●	●	●	●	
Aluminium sulphate	Al ₂ (SO ₄) ₃	60	●	●	●	●	●	●	●	●	○	
Ammonia, aqueous	NH ₄ OH	28	●	●	●	●	○	●	○	●	○	
Calcium hydroxide★ ⁷	Ca(OH) ₂		●	●	●	●	●	●	●	●	●	
Calcium hypochlorite	Ca(OCl) ₂	20	○	●	○	●	●	●	●	●	●	
Chromic acid★ ⁵	H ₂ CrO ₄	10	●	●	●	●	●	●	●	●	●	●
		30	○	●	○	●	○	●	○	●	●	
		40	○	●	○	●	○	●	○	●	●	
		50	○	●	○	●	○	●	○	●	●	
Copper sulphate	CuSO ₄	30	●	●	●	●	●	●	●	●	●	
Ferric chloride★ ³	FeCl ₃	100	●	●	○	●	●	●	●	●	●	
Ferric sulphate★ ³	Fe ₂ (SO ₄) ₃	100	●	●	●	●	●	●	●	●	●	
Ferrous chloride	FeCl ₂	100	●	●	○	●	●	●	●	●	●	
Ferrous sulphate	FeSO ₄	50	●	●	●	●	●	●	●	●	●	
Hydrochloric acid	HCl	<25	●	●	○	●	○	●	●	●	●	
		25 to 37	●	●	○	●	○	●	○	●	●	
Hydrogen peroxide	H ₂ O ₂	30	●	●	●	●	●	●	●	●	●	
		10	●	●	●	●	●	●	●	●	●	
		30	●	●	●	●	●	●	○	●	●	
Nitric acid	HNO ₃	40	○	●	●	●	●	●	○	●	●	
		70	○	●	○	●	○	●	○	●	●	
		70	○	●	○	●	○	●	○	●	●	
Peracetic acid	CH ₃ COOOH	5	●	●	○	●	○	●	●	●	●	
Potassium hydroxide	KOH	50	●	○	●	●	○	●	○	●	○	
Potassium permanganate	KMnO ₄	10	●	●	●	●	○	●	●	●	●	
Sodium chlorate	NaClO ₃	30	●	●	●	●	○	●	●	●	●	
Sodium chloride	NaCl	30	●	●	○	●	●	●	●	●	●	
Sodium chlorite	NaClO ₂	20	●	○	○	●	●	●	●	●	●	
Sodium hydroxide	NaOH	20	●	○	●	●	●	●	●	○	●	○
		30	●	○	●	●	●	●	○	●	○	
		50	●	○	●	●	●	●	○	●	○	
Sodium hypochlorite	NaOCl	20	○	●	○	●	●	●	●	●	●	
Sodium sulphide	Na ₂ S	30	●	●	●	●	●	●	●	●	○	
Sodium sulphite★ ⁶	Na ₂ SO ₃	20	●	●	●	●	●	●	●	●	○	
Sulphurous acid	H ₂ SO ₃	6	●	●	●	●	●	●	●	●	○	
Sulphuric acid★ ⁴	H ₂ SO ₄	<80	●	●	○	●	○	●	○	●	○	
		80 to 98	○	●	○	○	○	●	○	○	○	

- Resistant.
- Limited resistance.
- Not resistant.
- ★³ Risk of crystallization.
- ★⁴ Reacts violently with water and generates much heat. (Pump should be absolutely dry before dosing sulphuric acid.)
- ★⁵ Must be fluoride-free when glass balls are used.
- ★⁶ In neutral solutions.
- ★⁷ Saturated solution 0.1%.

WebCAPS

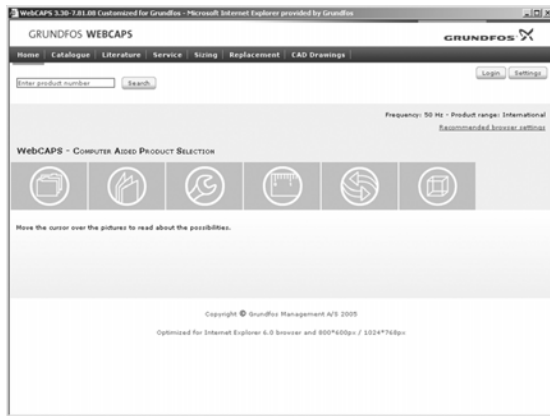

WebCAPS is a **Web-based Computer Aided Product Selection** program available on www.grundfos.com.

WebCAPS contains detailed information on more than 185,000 Grundfos products in more than 20 languages.

In WebCAPS, all information is divided into 6 sections:

- Catalogue
- Literature
- Service
- Sizing
- Replacement
- CAD drawings.

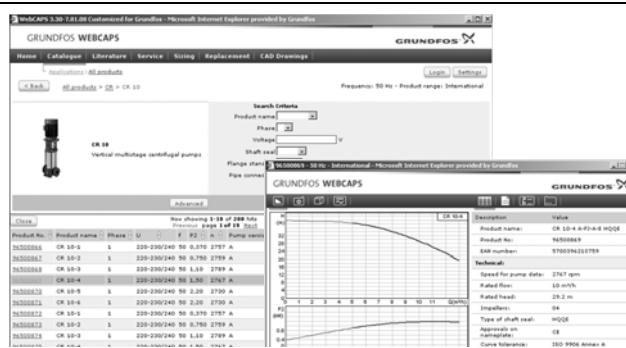

Catalogue

This section is based on fields of application and pump types, and contains

- technical data
- curves (QH, Eta, P1, P2, etc) which can be adapted to the density and viscosity of the pumped liquid and show the number of pumps in operation
- product photos
- dimensional drawings
- wiring diagrams
- quotation texts, etc.



Literature

In this section you can access all the latest documents of a given pump, such as

- data booklets
- installation and operating instructions
- service documentation, such as Service kit catalogue and Service kit instructions
- quick guides
- product brochures, etc.



Service

This section contains an easy-to-use interactive service catalogue. Here you can find and identify service parts of both existing and discontinued Grundfos pumps.

Furthermore, this section contains service videos showing you how to replace service parts.



Sizing

This section is based on different fields of application and installation examples, and gives easy step-by-step instructions in how to

- select the most suitable and efficient pump for your installation
- carry out advanced calculations based on energy consumption, payback periods, load profiles, life cycle costs, etc.
- analyse your selected pump via the built-in life cycle cost tool
- determine the flow velocity in wastewater applications, etc.



Replacement

In this section you find a guide to selecting and comparing replacement data of an installed pump in order to replace the pump with a more efficient Grundfos pump. The section contains replacement data of a wide range of pumps produced by other manufacturers than Grundfos.

Based on an easy step-by-step guide, you can compare Grundfos pumps with the one you have installed on your site. When you have specified the installed pump, the guide will suggest a number of Grundfos pumps which can improve both comfort and efficiency.

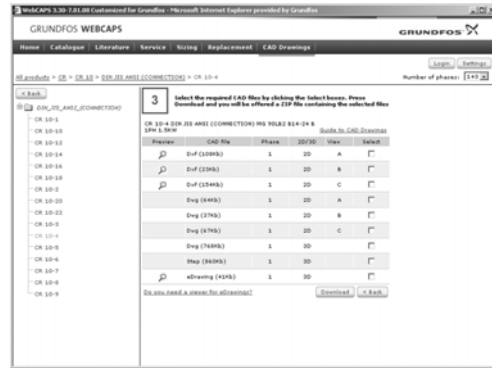

CAD drawings

In this section it is possible to download 2-dimensional (2D) and 3-dimensional (3D) CAD drawings of most Grundfos pumps.

These formats are available in WebCAPS:

2-dimensional drawings:

- .dxf, wireframe drawings
- .dwg, wireframe drawings.

3-dimensional drawings:

- .dwg, wireframe drawings (without surfaces)
- .stp, solid drawings (with surfaces)
- .eprt, E-drawings.

WinCAPS



Fig. 1 WinCAPS CD-ROM

WinCAPS is a **Windows-based Computer Aided Product Selection** program containing detailed information on more than 185,000 Grundfos products in more than 20 languages.

The program contains the same features and functions as WebCAPS, but is an ideal solution if no Internet connection is available.

WinCAPS is available on CD-ROM and updated once a year.

L-DDI-PG-01 10/06 (US)
Subject to alterations