

## DMI

**omd** ■ 800-648-3326  
oliver m. dean, inc. ■ [www.omdean.com](http://www.omdean.com)

Dosing

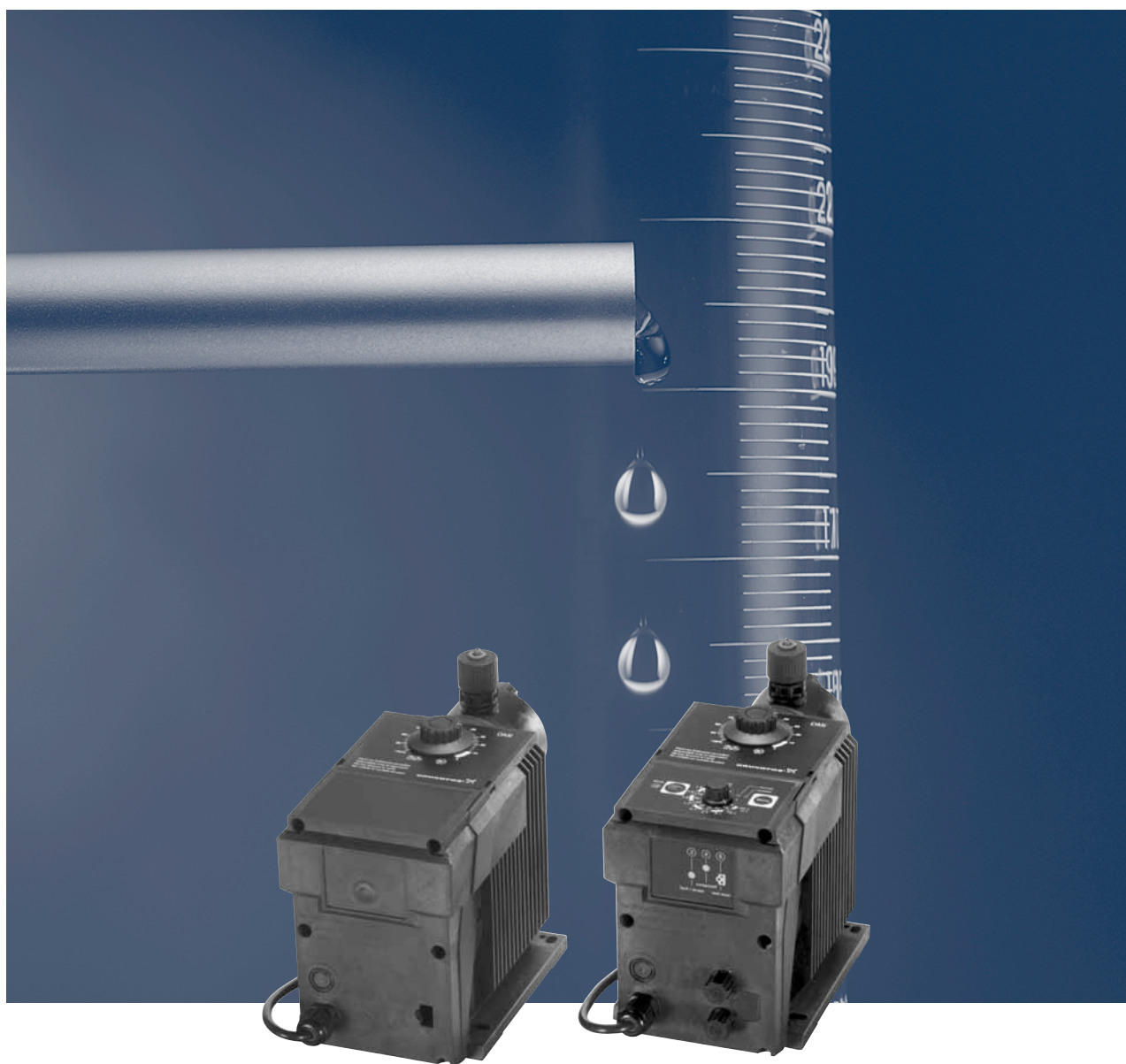

# Contents

---

## Features and benefits

DMI dosing pumps	3
Examples of applications	3

## Performance range

DMI	4
-----	---

## Identification

Type key	5
----------	---

## Functions

Control versions	6
Options	6
Functions	6
Capacity control	7

## Construction

General description	9
DMI with manual venting	9
DMI with Plus3 system	10
Functional principle of the Plus3 system	11
Spring-loaded valves	11

## Technical data

Dimensions	12
Performance data	14
Suction lift	15
Inlet pressure and back pressure	15
Permissible temperature range of the pumped media	16
Electrical data	16
Additional technical data	16

## Pump selection

DMI selection (0.095 to 5.7 gph)	17
----------------------------------	----

## Pumped liquids

List of pumped liquids	18
------------------------	----

## Further product documentation

WebCAPS	20
WinCAPS	21

## DMI dosing pumps

### Simple and cost-efficient dosing

from 0.095 to 5.7 GPH



Fig. 1 DMI, control version B

Fig. 2 DMI, control version A

### Variations on the synchronous-motor theme

The Grundfos DMI range of dosing pumps comprises several variants for general or specific dosing purposes. Dosing heads and valves are available in different materials to suit a wide range of general water treatment and industrial applications.

Whichever model you choose, you get a sturdy, cost-efficient pump based on a well-proven synchronous-motor design. The DMI range can dose rates from 0.095 to 5.7 GPH and pressures up to 232 psi.

### Silent operation

Regardless of model, the DMI pump is among the most silent of its type available on the market today. It keeps its noise levels down to just 45 dB(A).

### Flexible installation

The Grundfos DMI is suitable for both horizontal and vertical installation. If installed horizontally, the control elements are located on the unit's top for easy access.

### Proven synchronous-motor technology

The synchronous-motor technology used in the Grundfos DMI range combines robustness and precision. It keeps pulsation low and performance high.

### The DMI A or B: With or without signal inputs

The DMI range is suitable for a wide range of dosing tasks. Choose between control version B, designed for simple manual control, or control version A which offers more sophisticated control features. Examples include: Pulse control with multiplier/divisor that converts signals into strokes as appropriate; stroke-frequency control; access to check functions and venting, and optional memory function.

### Choose between control options

The DMI A (AR) series can be set to either proportional control or manual dosing by pressing a key. Pulse control mode allows proportional control according to external contact signals from a flow meter or other device.

### Examples of applications

- Industrial and municipal water treatment
- Cooling towers
- Industrial cleaning systems
- Cleaning in place (CIP) and disinfection (dairies, food and beverage, etc.)
- Paper production/finishing
- Chemical industry
- Chemigation
- Galvanic industry and surface treatment
- Plating
- Swimming pools
- Semiconductor industry.

## DMI

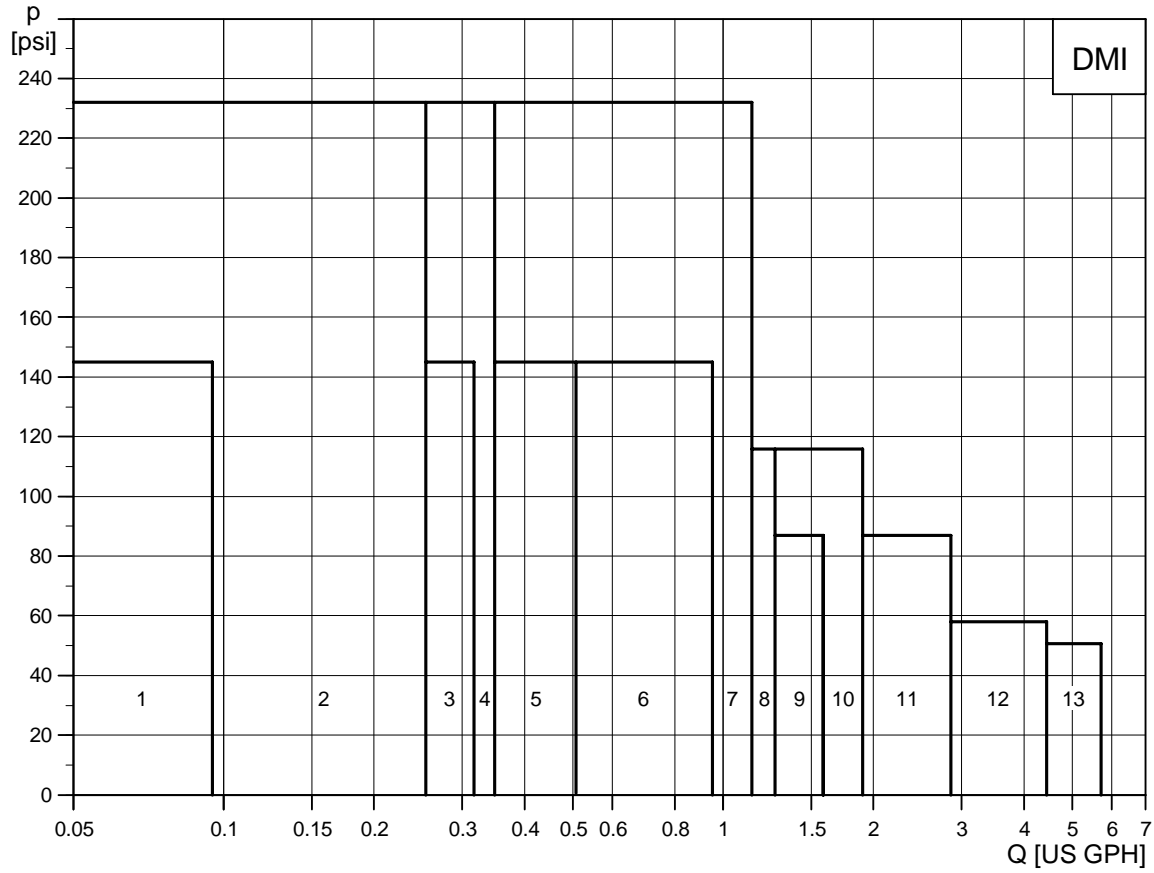

Fig. 3 Performance range, DMI

TM03 4488 2206

Pos.	Pump
1	DMI 0.3-10
2	DMI 0.8-16
3	DMI 1-10
4	DMI 1.1-16
5	DMI 1.6-10
6	DMI 3-10
7	DMI 3.6-16
8	DMI 4-8
9	DMI 5-6
10	DMI 6-8
11	DMI 9-6
12	DMI 14-4
13	DMI 18-4

## Type key

<b>Example:</b>	DMI	1.6	-10	A	PVC	/V	/G	-T	-H	1	33	B
<b>Type range</b>												
DMI												
<b>Maximum flow [l/h]</b>												
<b>Maximum pressure [bar]</b>												
<b>Control version</b>												
B	Without external control interface											
A	Internal frequency control, external contact signal control,											
AR	Internal frequency control, external contact signal control, alarm relay											
<b>Dosing head variant</b>												
PP	Polypropylene											
PV	PVDF (polyvinylidene fluoride)											
PVC	Polyvinyl chloride											
SS	Stainless steel, AISI 316											
PP-P3	PP with Plus <sup>3</sup>											
PVC-P3	PVC with Plus <sup>3</sup>											
<b>Gasket material</b>												
E	EPDM (ethylene propylene diene monomer)											
V	FKM (fluoroelastomer)											
T	PTFE (polytetrafluoroethylene, eg. Teflon®)											
<b>Valve ball material</b>												
C	Ceramic											
G	Glass											
T	PTFE (polytetrafluoroethylene, eg. Teflon®)											
SS	Stainless steel, AISI 316											
<b>Mains plug</b>												
X	No plug											
F	EU (Schuko)											
B	USA, Canada											
I	Australia, New Zealand, Taiwan											
E	Switzerland											
<b>Connection, suction/discharge</b>												
B6	Pipe 4/6 mm											
3	Tube 4/6 mm											
A5	Tube 5/8 mm											
4	Tube 6/9 mm											
6	Tube 9/12 mm											
S	Tube 0.375" / 0.5"											
A	Threaded Rp ¼"											
V	Threaded NPT ¼"											
A9	Threaded NPT ½", male											
B1	Tube 6/12 mm/cementing d. 12 mm											
B3	Welding d. 16 mm											
<b>Valve type</b>												
1	Standard											
2	Spring-loaded 0.7 psi inlet opening pressure 0.7 psi discharge opening pressure											
3	Spring-loaded 0.7 psi inlet opening pressure 11.6 psi discharge opening pressure											
4	Spring-loaded, discharge only 11.6 psi discharge opening pressure											
<b>Supply voltage</b>												
G	1 x 230 V, 50/60 Hz											
H	1 x 120 V, 50/60 Hz											
<b>Control panel position</b>												
T	Top-mounted											
X	No control panel											

## Control versions

Features	Control versions		
	B	A	AR
Stroke length adjustment	●	●	●
Internal frequency control		●	●
External contact signal control		●	●
Relay output			●



Fig. 4 DMI, control version B



Fig. 5 DMI, control version A

GrA1067

## Functions

Electronic function	Socket	Control version	
		A	AR
Relay function	Output socket 3	-	Stroke
Remote on/off	Input socket 4	NO	NO
Pre-empty signal	Input socket 5	NO	NO
Empty signal	Input socket 5	NO	NO
Error signal	Output socket 3	-	NO
Relay	Output socket 3	-	NO
Contact signal	Input socket 4	X	X
Hall sensor		-	-

1:1: Without multiplier/divisor function  
 NO: Normally open  
 NC: Normally closed

## Options

Pump	Plus <sup>3</sup> system*
DMI 0.3-10	●
DMI 0.8-16	●
DMI 1-10	●
DMI 1.1-16	●
DMI 1.6-10	●
DMI 3-10	●
DMI 3.6-10	●
DMI 4-8	●
DMI 5-6	●
DMI 6-8	●
DMI 9-6	
DMI 14-4	
DMI 18-4	

\* See page 11.

## Capacity control

The capacity can be controlled in three ways:

- by adjusting the stroke length
- by stroke frequency control
- by external pulse control.

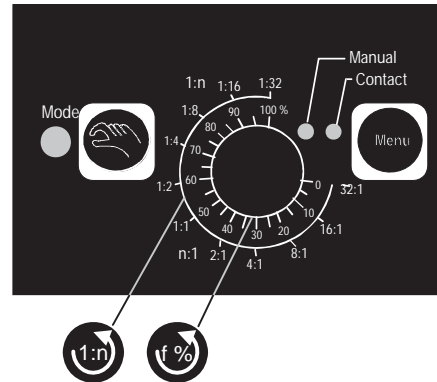
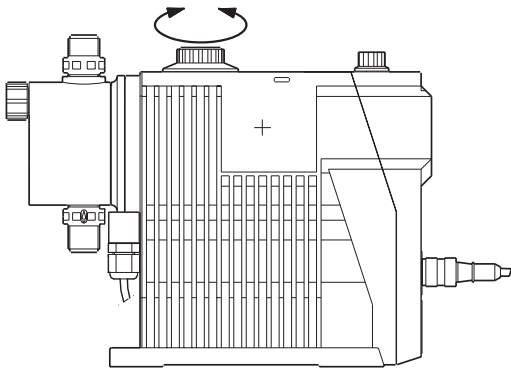

Fig. 6 Control and display elements, control version A

TM03 3647 0506

### Capacity control by adjusting the stroke length

The stroke length is adjusted by means of the stroke-length adjusting knob.



TM03 4643 0506

Fig. 7 Capacity control by adjusting the stroke length

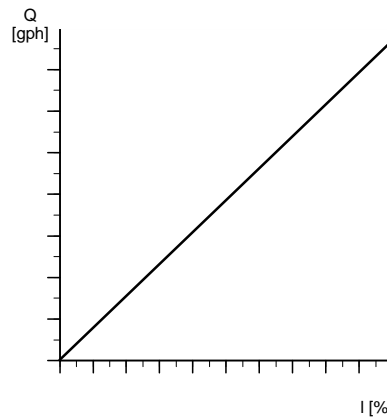

Fig. 8 Relation between stroke length (l) and capacity (Q)

TM03 3883 1106

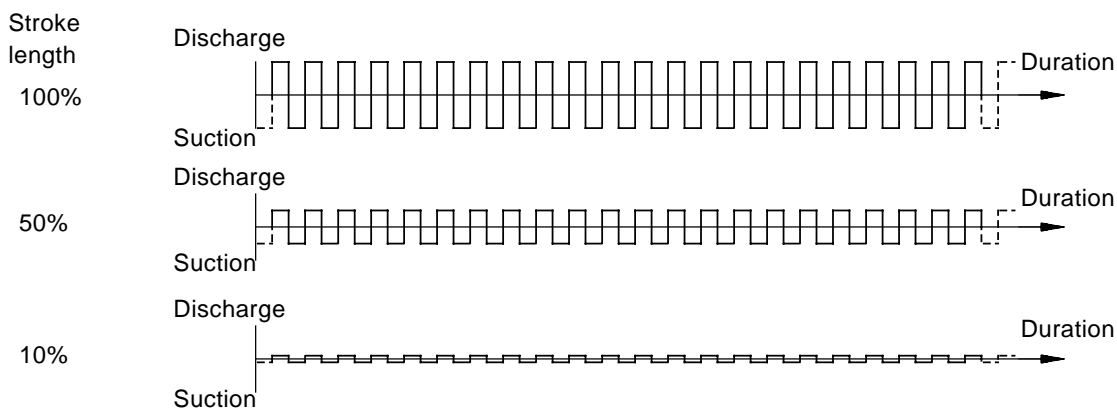
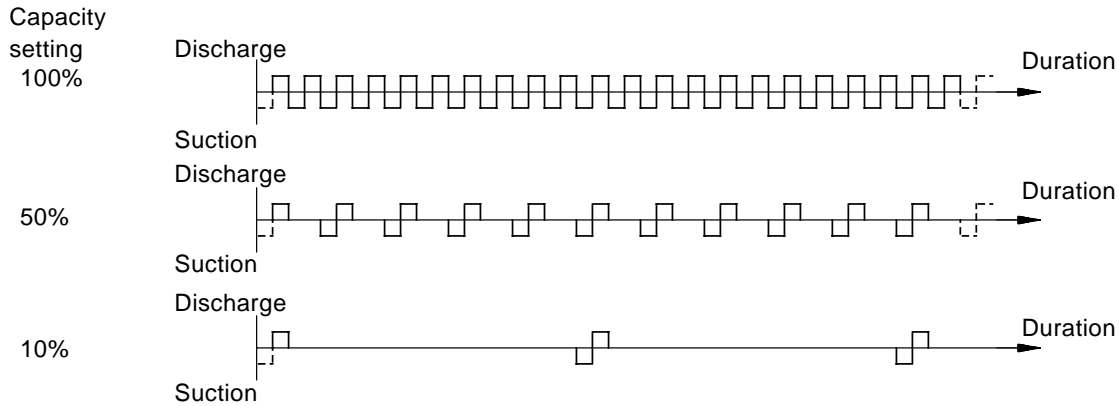

Fig. 9 Relation between stroke length and capacity

TM03 2074 3505

## Stroke frequency control

The suction and discharge stroke speeds are constant, while the stroke frequency varies according to the frequency set.



TM01 8945 0900

**Fig. 10** Dosing principle, control version B, internal frequency control

## External pulse control

Setting	Function	Number of strokes per contact signal	Example
1:1	1:1	The pump makes one dosing stroke per contact signal received.	One stroke per contact signal for the setting 1:1.
1:n	Multiplier	The pump makes the set number of dosing strokes per contact signal received.	16 strokes per contact signal for the setting 1:16.
n:1	Divisor	The pump makes one dosing stroke after the set number of contact signals has been received.	One stroke for every four contact signals for the setting 4:1.

## General description

The DMI pump is powered by an overload protected synchronous motor.

The DMI is available with several options on the pump head:

- manual venting (standard)
- Plus<sup>3</sup> system.

As an option, the pump can also be equipped with spring-loaded valves for viscous liquids.

## DMI with manual venting

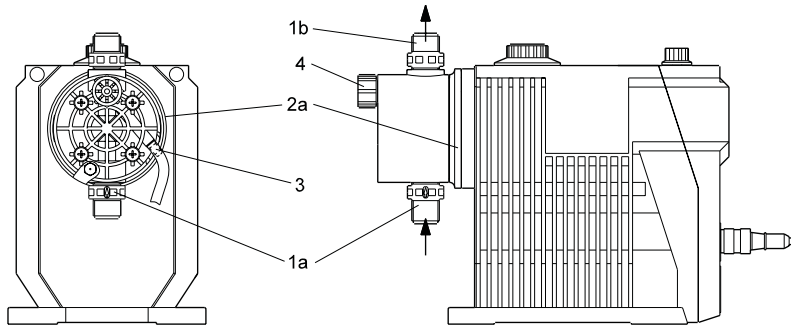

TM03 3623 0506

**Fig. 11** Sectional drawing, DMI with manual venting

## Legend

Pos.	Component
1a	Suction valve
1b	Discharge valve
2a	Dosing head with manual venting
3	Connection for venting line
4	Manual bleed/vent valve

## DMI with Plus<sup>3</sup> system

The Plus<sup>3</sup> system incorporates priming/deaeration and calibration system for moderately volatile liquids (chlorine bleaching agents).

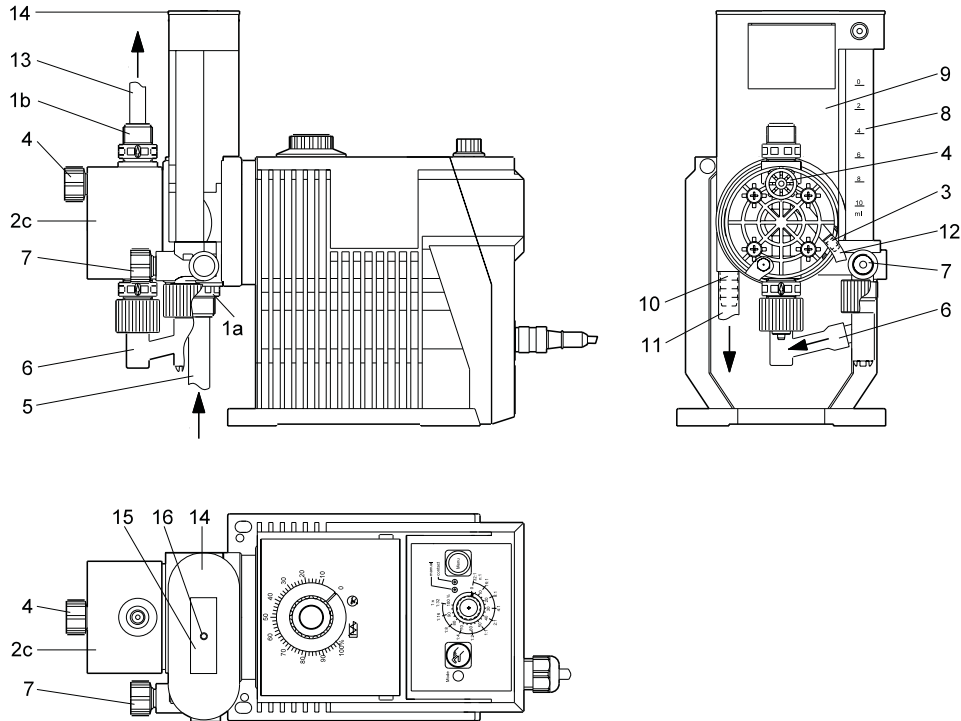

Fig. 12 Sectional drawing, DMI with Plus<sup>3</sup> system

### Legend:

Pos.	Component
1a	Suction valve
1b	Discharge valve
2c	Dosing head with Plus <sup>3</sup> system
3	Connection for venting line
4	Manual vent valve
5	Suction line from tank
6	Line from calibration tube (pos. 8) to dosing head (pos. 2c)
7	Isolating valve at calibration tube (pos. 8)
8	Calibration tube
9	Priming/deaeration chamber
10	Connection for overflow line (pos. 11)
11	Overflow line to the tank (PVC tube 8/11 mm)
12	Venting line to the tank
13	Dosing line (discharge line)
14	Cover
15	Adhesive label
16	Ventilation hole

TM03 3624 0506

## Functional principle of the Plus<sup>3</sup> system

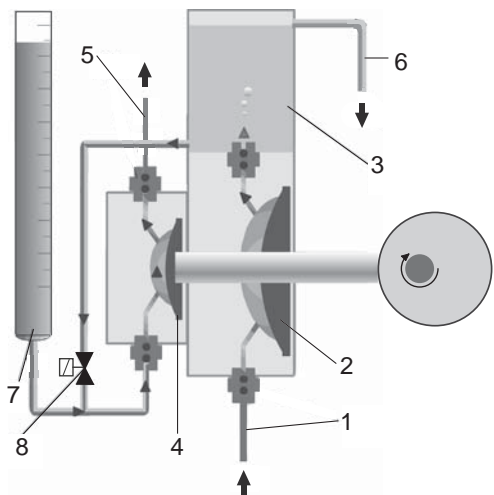

TM03 4500 2206

**Fig. 13** Functional principle of the Plus<sup>3</sup> system

### Legend:

Pos.	Component
1	Inlet from tank
2	Conveying diaphragm
3	Priming/deaeration chamber
4	Dosing diaphragm
5	Discharge to the process line
6	Deaeration bypass
7	Calibration tube
8	Calibration valve

### Operation of the Plus<sup>3</sup> system

- The conveying diaphragm (2) draws a large volume of liquid from the supply tank (1) and pumps it into the priming/deaeration chamber (3).
- Any gas bubbles in the liquid are vented to the atmosphere in the priming chamber.
- The separate, working diaphragm (4) pumps the liquid into the process line (5).
- Any excess liquid is returned to the tank via the deaeration bypass (6).
- The integrated calibration column (7) and calibration valve (8) allow precise adjustment of the flow while the pump is running.

Designed especially for volatile chemicals, the double-diaphragm system offers high process accuracy and cost-efficient operation.

An additional feature of the Plus<sup>3</sup> system is that the priming chamber allows the pump to be in a suction lift configuration. This permits the exchange of chemical tanks without interrupting the chemical discharge to the system.

### Spring-loaded valves

The pump head can be supplied with spring-loaded valves for improved performance when handling viscous liquids. Some of these valves have a larger nominal width and incorporate adapters.

**Note:** The suction and discharge dimensions of the pump may change when the pump is fitted with spring-loaded valves.

## Dimensions

### DMI

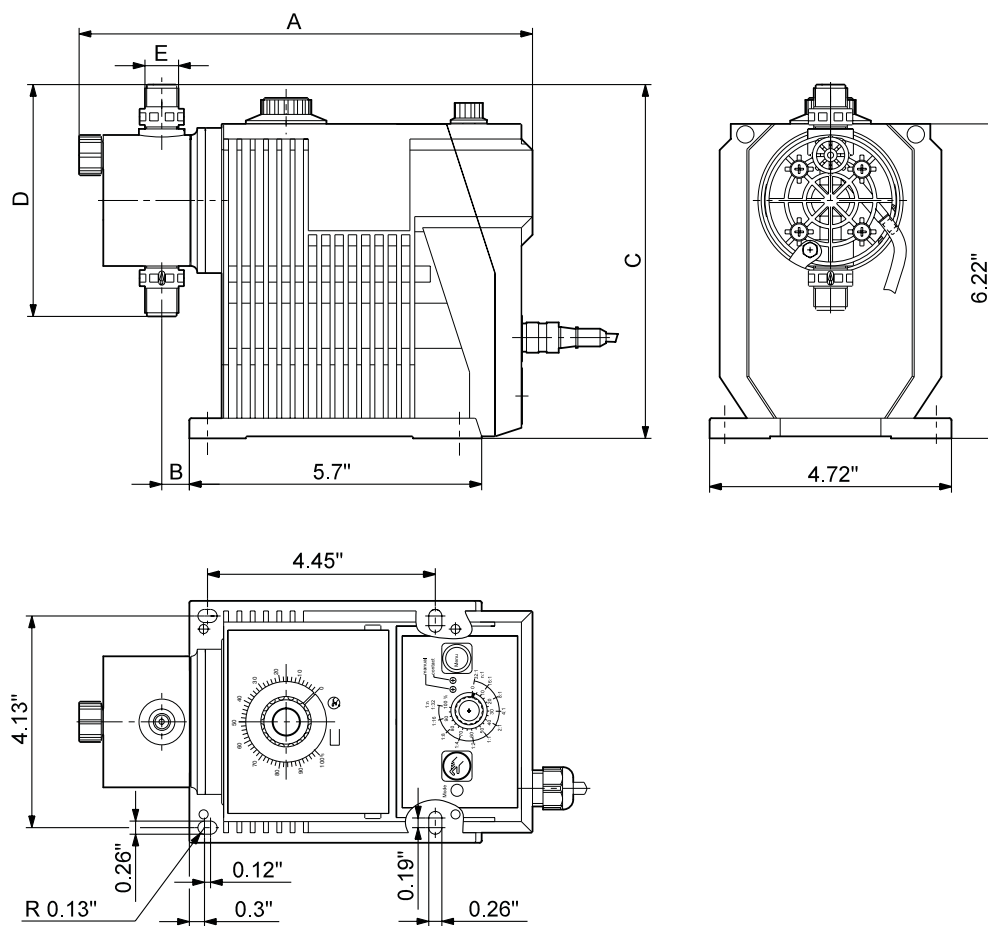

TM03 3904 1106

Fig. 14 Dimensions, DMI

### Dimensions [inches]

Pump	A	B	C	D	E	C HV*	D HV*	E HV*
DMI 0.3-10	8.86	0.81	6.91	4.41	G 3/8	6.91	4.41	G 3/8
DMI 0.8-16	8.86	0.81	6.91	4.41	G 3/8	8.17	6.93	G 5/8
DMI 1-10	8.86	0.81	6.91	4.41	G 3/8	8.17	6.93	G 5/8
DMI 1.1-16	8.86	0.81	6.91	4.41	G 3/8	8.17	6.93	G 5/8
DMI 1.6-10	8.86	0.81	6.91	4.41	G 3/8	8.17	6.93	G 5/8
DMI 3-10	8.86	0.81	6.91	4.41	G 3/8	8.17	6.93	G 5/8
DMI 3.6-16	8.86	0.81	6.91	4.41	G 3/8	8.17	6.93	G 5/8
DMI 4-8	8.86	0.81	6.91	4.41	G 3/8	8.17	6.93	G 5/8
DMI 5-6	8.86	0.81	6.91	4.41	G 3/8	8.17	6.93	G 5/8
DMI 6-8	8.86	0.81	6.91	4.41	G 3/8	8.17	6.93	G 5/8
DMI 9-6	9.06	1.05	7.26	5.24	G 3/8	7.26	5.24	G 5/8
DMI 14-4	9.06	1.05	7.26	5.24	G 3/8	7.26	5.24	G 5/8
DMI 18-4	9.06	1.05	7.26	5.24	G 3/8	7.26	5.24	G 5/8

\* HV = Pump version for high-viscosity liquids

## DMI with Plus<sup>3</sup> system

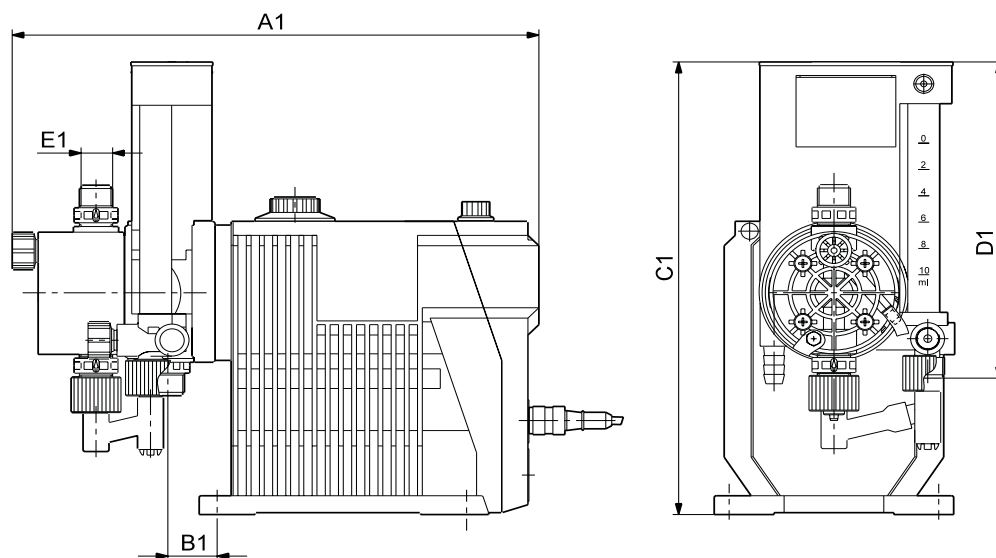

TM03 3481 0406

Fig. 15 Dimensions of DMI with Plus<sup>3</sup> system

### Dimensions [inches]

Pump	A1	B1	C1	D1	E1
DMI 0.3-10	10.28	0.99	9.88	7.78	G 3/8
DMI 0.8-16	10.28	0.99	9.88	7.78	G 3/8
DMI 1-10	10.28	0.99	9.88	7.78	G 3/8
DMI 1.1-16	10.28	0.99	9.88	7.78	G 3/8
DMI 1.6-10	10.28	0.99	9.88	7.78	G 3/8
DMI 3-10	10.28	0.99	9.88	7.78	G 3/8
DMI 3.6-16	10.28	0.99	9.88	7.78	G 3/8
DMI 4-8	10.28	0.99	9.88	7.78	G 3/8
DMI 5-6	-	-	-	-	-
DMI 6-8	10.28	0.99	9.88	7.78	G 3/8
DMI 9-6	-	-	-	-	-
DMI 14-4	-	-	-	-	-
DMI 18-4	-	-	-	-	-

## Performance data

Pump	Vstroke [cm <sup>3</sup> ]	60 Hz				
		Capacity <sup>1)</sup> [GPH]	Capacity <sup>1)</sup> [l/h]	Pmax <sup>2)</sup> [psi]	Pmax <sup>2)</sup> [bar]	Max. stroke rate [strokes/min]
DMI 0.3-10	0.04	0.095	0.36	145	10	144
DMI 0.8-16	0.11	0.254	0.96	232	16	144
DMI 1-10	0.14	0.317	1.2	145	10	144
DMI 1.1-16	0.15	0.349	1.32	232	16	144
DMI 1.6-10	0.22	0.507	1.92	145	10	144
DMI 3-10	0.42	0.925	3.5	102	7	144
DMI 3.6-16	0.5	1.14	4.32	189	13	144
DMI 4-8	0.55	1.27	4.8	116	8	144
DMI 5-6	0.69	1.58	6	72.5	5	144
DMI 6-8	0.84	1.902	7.2	87	6	144
DMI 9-6	1.24	2.853	10.8	80	5.5	144
DMI 14-4	1.92	4.439	16.8	44	3	144
DMI 18-4	2.5	5.7	21.6	44	3	144

1) Depending on the pump type, the maximum dosing flow of pumps with Plus<sup>3</sup> system is reduced by approx. 0.026 to 0.1 gph (0.1 to 0.4 l/h).

2) P<sub>max</sub> refers to dosing heads without automatic venting.  
With automatic venting, the P<sub>max</sub> is 14.5 psi (1 bar) less.

Performance data is measured at maximum pump back pressure.

The values in the table above are based on the these conditions:

- Water as the dosing liquid
- Suction lift of 1.6 ft head
- Fully vented dosing head
- Maximum stroke length.

Changes in temperature affecting the viscosity of the pumped liquid may cause additional friction losses and require a pump head fitted with spring-loaded valves.

The available pump capacity may be reduced up to 10% when handling fluids at the maximum viscosity.

### Turn-down ratio

The turn-down ratio depends on the control version.

Pumps with stroke length adjustment can operate from 10% to 100% of the maximum capacity.

Pumps with pulse control give you even more flexibility.

## Suction lift

Pump	Max. wet suction lift Continuous operation <sup>1)</sup> Viscosity similar to water [ft]		Max. dry suction lift Start-up <sup>2)</sup> Non-degassing water-like fluids [ft]		Max. viscosity [cps]		
	Standard	Plus <sup>3</sup> system	Standard	Plus <sup>3</sup> system	Standard	Plus <sup>3</sup> system	Spring-loaded valves <sup>3)4)</sup>
DMI 0.3-10	*	4.9	*	**	200	100	500
DMI 0.8-16	19.7	4.9	3.3	**	200	100	500
DMI 1-10	19.7	4.9	3.3	**	200	100	500
DMI 1.1-16	19.7	4.9	3.3	**	200	100	500
DMI 1.6-10	19.7	4.9	4.9	**	200	100	500
DMI 3-10	19.7	4.9	6.6	**	200	100	500
DMI 3.6-16	19.7	4.9	6.6	**	200	100	500
DMI 4-8	19.7	4.9	7.2	**	200	100	500
DMI 5-6	19.7	4.9	8.2	-	100	-	500
DMI 6-8	19.7	4.9	9.2	**	100	50	500
DMI 9-6	19.7	4.9	9.2	-	150	-	200
DMI 14-4	19.7	4.9	9.2	-	150	-	200
DMI 18-4	19.7	4.9	9.2	-	150	-	200

1) Dosing head and valves wetted (initial start-up)

2) Air vent valve open

3) Pump head with spring-loaded valves for improved performance when handling viscous liquids

4) The max. permissible viscosities apply to all valve combinations with a spring-loaded valve with an inlet opening pressure of 0.7 psi (valve combination 2 and 3 - see type key, page 5.)

\* Flooded suction only

\*\* Pumps incorporating the Plus<sup>3</sup> system are delivered with special start-up device; consequently, the max. suction lift at start-up is not a problem

## Inlet pressure and back pressure

Pump	Max. inlet pressure				Min. required back pressure			
	Standard		Plus <sup>3</sup> System		Standard		Plus <sup>3</sup> System	
	[psi]	[bar]	[psi]	[bar]	[psi]	[bar]	[psi]	[bar]
DMI 0.3-10	2.9	0.2	*	*	14.5	1	14.5	1
DMI 0.8-16	2.9	0.2	*	*	14.5	1	14.5	1
DMI 1-10	2.9	0.2	*	*	14.5	1	14.5	1
DMI 1.1-16	2.9	0.2	*	*	14.5	1	14.5	1
DMI 1.6-10	2.9	0.2	*	*	14.5	1	14.5	1
DMI 3-10	2.9	0.2	*	*	14.5	1	14.5	1
DMI 3.6-16	2.9	0.2	*	*	14.5	1	14.5	1
DMI 4-8	2.9	0.2	*	*	14.5	1	14.5	1
DMI 5-6	2.9	0.2	*	*	14.5	1	14.5	1
DMI 6-8	2.9	0.2	*	*	14.5	1	14.5	1
DMI 9-6	2.9	0.2	*	*	14.5	1	14.5	1
DMI 14-4	2.9	0.2	*	*	14.5	1	14.5	1
DMI 18-4	2.9	0.2	*	*	14.5	1	14.5	1

\* The pump should be installed without inlet pressure.

## Permissible temperature range of the pumped media

The pumped media must be liquid. Exceeding the permissible temperatures may cause malfunction or damage to the pump.

Dosing head material	Permissible temperature range [°F]	
	p < 145 psi (10 bar)	p < 232 psi (16 bar)
PVC	32 to 104	32 to 68
Stainless steel, AISI 316Ti*	14 to 158	14 to 158
PP	32 to 104	-
PVDF**	14 to 140	14 to 68

\* Short-term resistance (15 min.) to 248°F at a back pressure of max. 229 psi.

\*\* At 158°F, the max. back pressure is 43 psi

## Electrical data

Pump	DMI 0.3-10	DMI 0.8-16
	DMI 1-10	DMI 1.1-16
	DMI 1.6-10	DMI 3.6-16
	DMI 3-10	DMI 5-6
	DMI 4-8	DMI 6-8
		DMI 9-6
		DMI 14-4
		DMI 18-4
Supply voltage	115 V ±10%, 50/60 Hz	
	230 V ±10%, 50/60 Hz	
Motor, synchronous motor with gear reduction	Maximum power consumption [W]	11
	Maximum current consumption [A]	at 115 V
at 230 V		0.048
Enclosure class	IP 65	

## Additional technical data

Accuracy <sup>1)</sup>	Dosing flow fluctuation	< ±1.5% of full scale value within the control range 10% to 100%
	Linearity deviation	± 4% of full scale value within the control range 20% to 100%
Weight	Standard version	6.4 lbs (2.9 kg)
Sound pressure level	Tested according to DIN 45635-01-KL3	± 45 dB(A)
Temperatures	Permissible ambient temperature	32°F to 104°F
	Permissible storage temperature	14°F to 104°F
Humidity	Max. relative humidity	92% (non-condensing)
Special features	Plus <sup>3</sup> system	Designed for handling sodium hypochlorite and other degassing fluids
	Spring-loaded valves	Valves for viscous liquids

1) The accuracy is based on the following conditions:

- water as the dosing liquid
- fully vented dosing head
- standard pump version.

## DMI selection (0.095 to 5.7 gph)

The example in bold is a **DMI 4-8 B-PP/V/G-X-H133B**

Max. capacity and pressure	Control variant	Materials of dosing head, gaskets and valve balls	Control panel position	Motor voltage	Valve type	Connection, suction/discharge	Mains plug
[l/h] - [bar]	B = Manual stroke length adjustment, 10-100%	<b>Dosing head version:</b> PP = Polypropylene PV = PVDF PVC= Polyvinyl chloride SS = Stainless steel, AISI 316	<b>Control panel position</b> T = Top mounted (variants A, AR) X = No control panel (variant B)	<b>Motor voltage</b> H = 1 x 120 V, 50/60 Hz	<b>Valve type</b>	<b>Connection, suction/discharge</b> 3 = Tube 4/6 mm B1 = Tube 6/12 mm / cementing d. 12 mm A9 = Threaded NPT 1/2", male S = Tube 3/8" / 1/2" V = Threaded NPT 1/4", female	<b>Mains plug</b> B = USA and Canada, 120 V
	A = Pulse control, remote on/off	PVC-P3 = PVC + Plus <sup>3</sup> system	<b>Motor voltage</b> H = 1 x 120 V, 50/60 Hz				
	AR = Pulse control, remote on/off, alarm output	<b>Gasket material:</b> E = EPDM V = FKM T = PTFE	<b>Valve type</b> 1 = Standard 2 = Spring-loaded, 0.7 psi inlet/discharge opening pressure 3 = Spring-loaded, 0.7 psi inlet opening pressure 11.6 psi discharge opening pressure 4 = Spring-loaded discharge, 11.6 psi opening pressure				
		<b>Valve ball material:</b> C = Ceramic G = Glass SS = Stainless steel, AISI 316					
[l/h] - [bar]	Control variant	Materials of dosing head, gaskets and valve balls	Control panel position	Motor voltage	Valve type	Connection, suction/discharge	Mains plug
<b>P &lt; 145 psi</b>							
0.3-10		<b>PP/V/G</b>			<b>1</b>	<b>3</b>	
1-10		PV/T/C	T		2	B1	
1.6-10		PVC/E/C	X	H	3	A9	<b>B</b>
3-10		PVC/V/G			4	S	
<b>4-8</b>	<b>B</b>					V	
5-6	A						
6-8	AR						
9-6		<b>SS/T/SS</b>	T		<b>1</b>	<b>A9</b>	
14-4		SS/V/SS	X	H	2	V	<b>B</b>
18-4					3		
					4		
<b>P &lt; 232 psi</b>							
		<b>PP/V/G</b>			<b>1</b>	<b>3</b>	
		PVC/E/C	T		2	B1	
0,8-16	B	PVC/V/G	X	H	3	A9	<b>B</b>
1.1-16	A				4	S	
3.6-16	AR					V	
		<b>SS/T/SS</b>	T		<b>1</b>	<b>A9</b>	
		SS/V/SS	X	H	2	V	<b>B</b>
					3		
					4		
<b>DMI with Plus<sup>3</sup>: P &lt; 145 psi</b>							
0,8-16	B	<b>PVC-P3/E/C</b>	T		<b>1</b>	<b>3</b>	
1.1-16	A	PVC-P3/V/G	X	H	2	B1	
3.6-16	AR				3	A9	<b>B</b>
					4	S	
						V	

## List of pumped liquids

This table is intended as a general guide only on the resistance of materials (at room temperature) to the liquids listed. The table cannot replace actual testing of the pumped liquids and pump materials under specific working conditions.

The list should, however, be applied with some caution as factors such as purity, temperature, abrasive particles, etc. may affect the chemical resistance of a specific material.

**Note:** Some of the liquids in this table may be toxic, corrosive or hazardous. Be careful when handling the liquids.

Pumped liquid (68°F)		Concentration %	Materials									
			Pump housing				Gasket			Ball		
Designation	Chemical formula		PP	PVDF	Stainless steel, AISI 316	PVC	FKM	EPDM	PTFE	Centellen C	Ceramic	Glass
Acetic acid	CH <sub>3</sub> COOH	25	●	●	●	●	-	●	●	●	●	●
		60	●	●	●	●	-	○	●	○	●	●
		85	●	●	●	-	-	-	●	○	●	●
Aluminium chloride	AlCl <sub>3</sub>	40	●	●	-	●	●	●	●	●	●	
Aluminium sulphate	Al <sub>2</sub> (SO <sub>4</sub> ) <sub>3</sub>	60	●	●	●	●	●	●	●	●	-	
Ammonia, aqueous	NH <sub>4</sub> OH	28	●	●	●	●	-	●	●	○	●	-
Calcium hydroxide★ <sup>7</sup>	Ca(OH) <sub>2</sub>		●	●	●	●	●	●	●	●	●	●
Calcium hypochlorite	Ca(OCl) <sub>2</sub>	20	○	●	-	●	●	●	●	●	●	●
Chromic acid★ <sup>5</sup>	H <sub>2</sub> CrO <sub>4</sub>	10	●	●	●	●	●	●	●	●	●	●
		30	-	●	-	●	●	○	●	○	●	●
		40	-	●	-	●	●	-	●	○	●	●
		50	-	●	-	●	●	-	●	○	●	●
Copper sulphate	CuSO <sub>4</sub>	30	●	●	●	●	●	●	●	●	●	
Ferric chloride★ <sup>3</sup>	FeCl <sub>3</sub>	100	●	●	-	●	●	●	●	●	●	
Ferric sulphate★ <sup>3</sup>	Fe <sub>2</sub> (SO <sub>4</sub> ) <sub>3</sub>	100	●	●	●	●	●	●	●	●	●	
Ferrous chloride	FeCl <sub>2</sub>	100	●	●	-	●	●	●	●	●	●	
Ferrous sulphate	FeSO <sub>4</sub>	50	●	●	●	●	●	●	●	●	●	
Hydrochloric acid	HCl	<25	●	●	-	●	○	●	●	●	●	●
		25 to 37	●	●	-	●	-	●	●	○	●	●
Hydrogen peroxide	H <sub>2</sub> O <sub>2</sub>	30	●	●	●	●	●	●	●	●	●	●
		10	●	●	●	●	●	●	●	●	●	●
Nitric acid	HNO <sub>3</sub>	30	●	●	●	●	●	●	●	-	●	●
		40	○	●	●	●	●	●	●	-	●	●
		70	-	●	●	-	●	-	●	-	●	●
Peracetic acid	CH <sub>3</sub> COOOH	5	●	●	-	●	-	●	●	●	●	
Potassium hydroxide	KOH	50	●	-	●	●	-	●	●	○	●	-
Potassium permanganate	KMnO <sub>4</sub>	10	●	●	●	●	-	●	●	●	●	●
Sodium chlorate	NaClO <sub>3</sub>	30	●	●	●	●	○	●	●	●	●	●
Sodium chloride	NaCl	30	●	●	-	●	●	●	●	●	●	●
Sodium chlorite	NaClO <sub>2</sub>	20	●	○	-	-	●	●	●	●	●	●
		20	●	○	●	●	●	●	●	○	●	-
		30	●	-	●	●	●	●	●	○	●	-
Sodium hydroxide	NaOH	50	●	-	●	●	●	●	●	○	●	-

Pumped liquid (68°F)			Materials									
			Pump housing				Gasket				Ball	
Designation	Chemical formula	Concentration %	PP	PVDF	Stainless steel, AISI 316	PVC	FKM	EPDM	PTFE	Centellen C	Ceramic	Glass
			Sodium hypochlorite	NaOCl	20	○	●	-	●	●	●	●
Sodium sulphide	Na <sub>2</sub> S	30	●	●	●	●	●	●	●	●	●	-
Sodium sulphite★ <sup>6</sup>	Na <sub>2</sub> SO <sub>3</sub>	20	●	●	●	●	●	●	●	●	●	-
Sulphurous acid	H <sub>2</sub> SO <sub>3</sub>	6	●	●	●	●	●	●	●	●	●	○
Sulphuric acid★ <sup>4</sup>	H <sub>2</sub> SO <sub>4</sub>	<80	●	●	-	○	●	○	●	○	●	○
		80 to 98	○	●	-	-	●	-	●	●	●	-

● Resistant.  
 ○ Limited resistance.  
 - Not resistant.

★3 Risk of crystallisation.  
 ★4 Reacts violently with water and generates much heat.  
 Pump should be absolutely dry before dosing sulphuric acid.)  
 ★5 Must be fluoride-free when glass balls are used.  
 ★6 In neutral solutions.  
 ★7 Saturated solution 0.1%.





## Sizing

This section is based on different fields of application and installation examples, and gives easy step-by-step instructions in how to

- select the most suitable and efficient pump for your installation
- carry out advanced calculations based on energy consumption, payback periods, load profiles, life cycle costs, etc.
- analyse your selected pump via the built-in life cycle cost tool
- determine the flow velocity in wastewater applications, etc.



## Replacement

In this section you find a guide to selecting and comparing replacement data of an installed pump in order to replace the pump with a more efficient Grundfos pump. The section contains replacement data of a wide range of pumps produced by other manufacturers than Grundfos.

Based on an easy step-by-step guide, you can compare Grundfos pumps with the one you have installed on your site. When you have specified the installed pump, the guide will suggest a number of Grundfos pumps which can improve both comfort and efficiency.

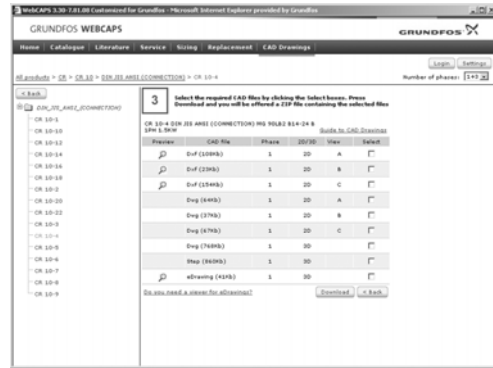

## CAD drawings

In this section it is possible to download 2-dimensional (2D) and 3-dimensional (3D) CAD drawings of most Grundfos pumps.

These formats are available in WebCAPS:

2-dimensional drawings:

- .dxf, wireframe drawings
- .dwg, wireframe drawings.

3-dimensional drawings:

- .dwg, wireframe drawings (without surfaces)
- .stp, solid drawings (with surfaces)
- .eprt, E-drawings.

## WinCAPS



Fig. 1 WinCAPS CD-ROM

WinCAPS is a **Windows-based Computer Aided Product Selection** program containing detailed information on more than 185,000 Grundfos products in more than 20 languages.

The program contains the same features and functions as WebCAPS, but is an ideal solution if no Internet connection is available.

WinCAPS is available on CD-ROM and updated once a year.





L-DMI-PG-01 08/06 (US)  
Subject to alterations

**GRUNDFOS Pumps Corporation**  
17100 West 118th Terrace  
Olathe, Kansas 66061  
Phone: +1-913-227-3400  
Telefax: +1-913-227-3500

**GRUNDFOS Canada Inc.**  
2941 Brighton Road  
Oakville, Ontario L6H 6C9 Canada  
Phone: +1-905 829 9533  
Telefax: +1-905 829 9512

**Bombas GRUNDFOS de Mexico S.A. de C.V.**  
Boulevard TLC No. 15  
Parque Industrial Stiva Aeropuerto  
Apodaca, N.L. Mexico 66600  
Phone: +52-81-8144 4000  
Telefax: +52-81-8144 4010