

# ***Fristam*** **PUMPS**

**INSTRUCTION AND MAINTENANCE MANUAL:**

**FM SERIES PUMP**

**omd** ■ 800-648-3326  
oliver m. dean, inc. ■ [www.omdean.com](http://www.omdean.com)



**SANITARY CENTRIFUGAL PUMPS**

## DESCRIPTION

This manual contains installation, operation, assembly, disassembly and repair instructions for the Fristam FM multi-stage pump.

The motors are standard NEMA totally enclosed fan cooled (TEFC) motors. These motors do require feet. Replacement motors are readily available from local motor distributors.

**CAUTION:** BEGIN ALL PUMP MAINTENANCE OPERATIONS BY DISCONNECTING THE ENERGY SOURCE TO THE PUMP. OBSERVE ALL LOCK OUT/TAG OUT PROCEDURES AS OUTLINED BY ANSI Z244.1-1982 AND OSHA 1910.147 TO PREVENT ACCIDENTAL START-UP AND INJURY.

## TABLE OF CONTENTS

TECHNICAL INFORMATION .....	4-5
PREVENTIVE MAINTENANCE.....	5
INSTALLATION .....	6-9
SHAFT ALIGNMENT.....	8
ELECTRICAL INSTALLATION .....	9
WATER FLUSH INSTALLATION .....	9
START-UP INSTRUCTIONS .....	9
PARTS LIST.....	10-12
ASSEMBLY DRAWINGS .....	10-14
FM3 (HP3) SEAL ASSEMBLY .....	10
FM5 (HP4) SEAL ASSEMBLY .....	11
FM3 EXPLODED PUMP HEAD ASSEMBLY .....	12
FM5 EXPLODED PUMP HEAD ASSEMBLY .....	13
EXPLODED BEARING BLOCK ASSEMBLY.....	14
SEAL REPLACEMENT .....	16-19
PUMP HEAD DISASSEMBLY .....	16
PUMP HEAD ASSEMBLY .....	17-19
SHAFT AND/OR BEARING REPLACEMENT .....	20-22
BEARING BLOCK DISASSEMBLY.....	20
BEARING BLOCK ASSEMBLY .....	21-22
CHECKING THE IMPELLER GAP.....	23
WARRANTY.....	24

## TECHNICAL INFORMATION

### SPECIFICATIONS

---

Maximum Inlet Pressure .....	1000 PSI
Temperature Range .....	-40°F - 400°F
Noise Level.....	60 - 85 dB(A)

### STANDARD MATERIALS OF CONSTRUCTION (NOTE: OTHER OPTIONS AVAILABLE)

---

Product Contact Components.....	AISI 316L Stainless Steel
Pump Seal Components	
Single Rotating Seal .....	316L Stainless Steel with Silicon Carbide Insert (silver/gray)
Stationary Seals .....	Silicon Carbide (black)
Double Rotating Seal.....	Carbon (white)
Product Contact Surface Finish.....	.32 in R <sub>a</sub>
Gaskets / O-rings .....	Viton
Bearing Block .....	Cast Iron

### SEAL INFORMATION

---

Double Mechanical	
Recommended Seal Flush Pressure.....	5 PSI Maximum
Recommended Seal Flush Flow.....	1-2 Gallons per Hour

### RECOMMENDED TORQUE VALUES

---

Cover Nuts .....	105 ft-lbs
Impeller Nut	
FM3 .....	40 ft-lbs
FM5 .....	90 ft-lbs
Seal Retaining Ring Bolts .....	5 ft-lbs
Seal Driver Set Screw (FM3 only).....	10 in-lbs
Housing Bolts .....	50 ft-lbs
Bearing Cap Bolts .....	10 ft-lbs
Bearing Locknut.....	50 ft-lbs

### IMPELLER GAPS (IMPELLER TO HOUSING)

---

All FM Pumps .....	0.8-1.0 mm ( 0.030-0.040”)
--------------------	----------------------------

### LUBRICATION

---

Bearing Block Oil	
FM3 .....	ISO VG 46
FM5 .....	ISO VG 68

## **TOOLS FOR ASSEMBLY & DISASSEMBLY**

---

7/16" socket .....	Seal Retaining Ring Bolts
Ratchet .....	For loosening bolts
Torque wrench.....	For proper tightening
Adjustable pliers .....	For removing Water Pipes
Chain wrench.....	For holding the Shaft when tightening & loosening the Impeller Nut
Food grade lubricant .....	For lubricating o-rings & gaskets
Standard screwdriver.....	For installing & removing the Bearing Lockwasher
Soft-face hammer .....	For installing & removing the Shaft
Feeler gages .....	For gapping the Impeller
<b>FM3 Tools</b>	
15/16" socket .....	Cover Nuts
1" socket .....	Impeller Nut
3/32" Allen wrench socket.....	Double Seal Driver Set Screw
3/4" socket .....	Housing Bolts
1/2" socket .....	Bearing Cap Bolts
M50 Spanner wrench .....	Bearing Locknut
<b>FM5 Tools</b>	
24mm socket .....	Cover Nuts
32mm socket .....	Impeller Nut
18mm socket .....	Housing Bolts
13mm socket .....	Bearing Cap Bolts
M65 Spanner wrench .....	Bearing Locknut

## **RECOMMENDED PREVENTIVE MAINTENANCE**

### **RECOMMENDED SEAL MAINTENANCE**

---

Visually inspect mechanical seal daily for leakage.  
 Replace mechanical seal annually under normal duty.  
 Replace mechanical seal as often as required under heavy duty.

### **ELASTOMER INSPECTION**

---

Inspect all elastomers when performing pump maintenance. We recommend replacing elastomers (o-rings and gaskets) during seal, pump shaft and/or motor replacement.

### **LUBRICATION**

---

The oil level should be maintained to the center of the sight glass on the side of the bearing block. The oil should be changed every 2,000 hours or 3 months under normal operating conditions. Make sure the oil drain pipe and cap are properly tightened to prevent any oil leakage from the bearing block.

### **MOTOR MAINTENANCE**

---

Consult motor manufacturer for recommended maintenance.

## INSTALLATION

### UNPACKING

Check the contents and all wrapping when unpacking the pump. Inspect the pump carefully for any damage that may have occurred during shipping. Immediately report any damage to the carrier. Remove the shaft guard and rotate the pump shaft by hand to make sure the impeller rotates freely. Keep the protective caps over the pump inlet and outlet in place until you are ready to install the pump.

### INSTALLING

Prior to actually installing the pump, ensure that:

- The pump will be readily accessible for maintenance, inspection and cleaning.
- Adequate ventilation is provided for motor cooling.
- The drive and motor type is suitable for the environment where it is to be operated. Pumps intended for use in hazardous environments (i.e. explosive, corrosive, etc.) must use a motor and drive with the appropriate enclosure characteristics. Failure to use an appropriate motor type may result in serious damage and/or injury.

### PIPING GUIDELINES

This section describes good piping practices to obtain maximum efficiency and service life from your pump.

Maximum performance and trouble-free operation require adherence to good piping practices.

#### FIGURE 1

Ensuring proper piping support and alignment at both the suction inlet and discharge outlet can help prevent serious damage to the pump housing.

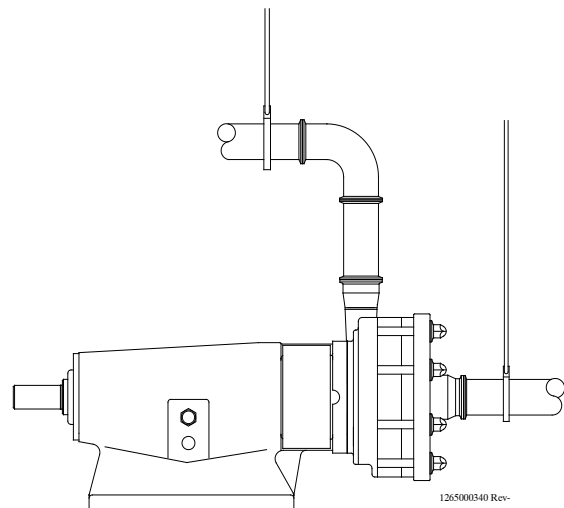

#### FIGURE 2

Avoid abrupt transitions in the piping system.  
 Avoid throttling valves in the suction piping.  
 Keep suction lines as short and direct as possible.  
 Ensure that the NPSH available in the system is greater than NPSH required by the pump.

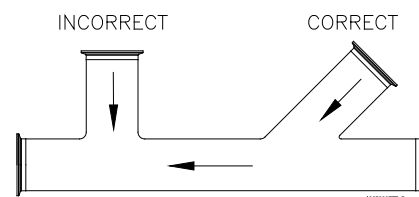

**FIGURE 3**

Avoid sump areas where sediments may collect.

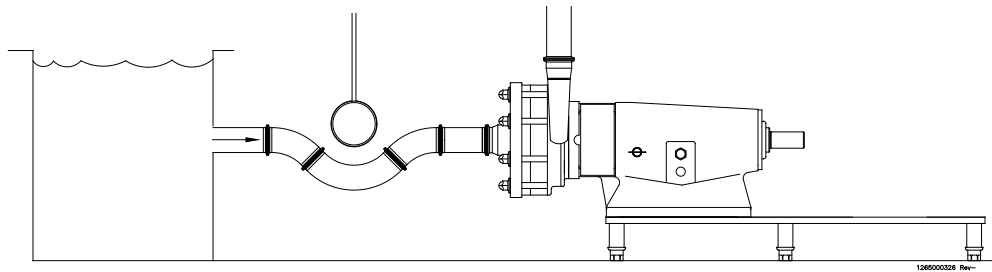

**FIGURE 4**

Avoid the formation of air pockets in the piping.

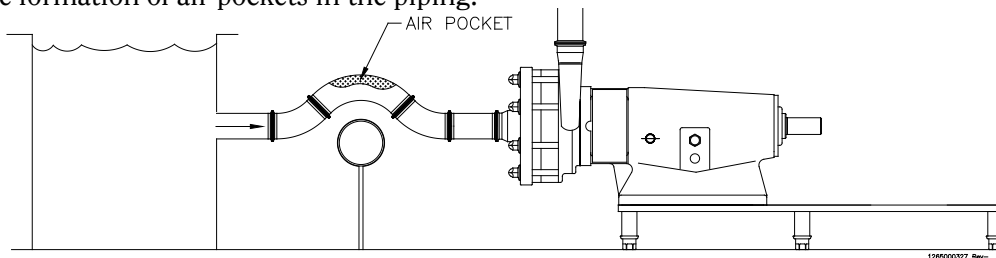
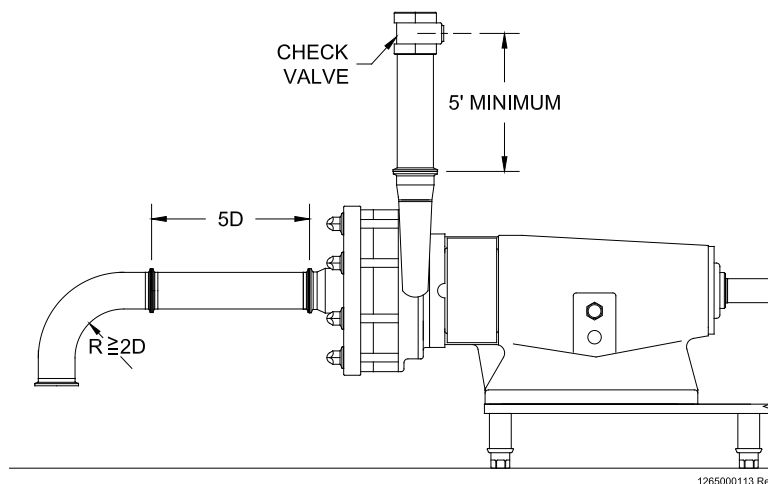

**FIGURE 5**

Avoid abrupt closure of shut-off valves, this may cause hydraulic shock which can cause severe damage to the pump and system.

Avoid elbows in the suction line if possible. When necessary they should be located 5 pipe diameters away from the pump inlet, and have a bend radius greater than 2 pipe diameters.

Check valves in discharge line should be a minimum of 5 ft. away from the pump outlet.



## ALIGNMENT

In most cases, the pump will be shipped with a drive unit mounted on a baseplate. The drive and pump are aligned at the factory; however, this alignment should be checked after installation (Figure 6). Misalignment between the pump and drive can result in premature bearing failure or other damage. If the pump is not shipped with a drive unit, use a flexible coupling between the pump and drive unit. Align the pump and drive unit according to the coupling requirements.

To check the alignment:

- Remove the wire ring from the coupling sleeve and let it hang between the sleeve and one of the flanges.
- To check the parallel alignment place a straight edge across the two coupling flanges and measure the maximum offset at various points around the periphery of the coupling without rotating the coupling. If the maximum offset exceeds the figure shown under “Parallel” in the table, realign the shafts.
- Check the angular alignment with a micrometer or caliper. Measure from the outside of one flange to the outside of the other (“Y”) at intervals around the periphery of the coupling. Determine the maximum and minimum dimensions without rotating the coupling. The difference between the maximum and minimum must not exceed the figure given under “Angular” in the table. If a correction is necessary be sure to recheck the parallel alignment.
- Reinstall the wire ring on the O.D. of the coupling sleeve.

### WOODS SURE-FLEX COUPLING ALIGNMENT

Sleeve Size	Type E			Type E		
	Parallel A	Angular Y max. - Y min.	Y*	Parallel A	Angular Y max. - Y min.	Y*
6	0.015"	0.070"	2.375"	0.015"	0.070"	2.375"
7	0.020"	0.081"	2.563"	0.020"	0.081"	2.563"
8	0.020"	0.094"	2.938"	0.020"	0.094"	2.938"
9	0.025"	0.109"	3.500"	0.025"	0.109"	3.500"
10	0.025"	0.128"	4.063"	0.025"	0.128"	4.063"
11	0.032"	0.151"	4.875"	0.032"	0.151"	4.875"
12	0.032"	0.175"	5.688"	0.032"	0.175"	5.688"
13	0.040"	0.195"	6.688"	0.040"	0.195"	6.688"
14	0.045"	0.242"	7.750"	0.045"	0.242"	7.750"

\* The “Y” dimension is shown for reference.

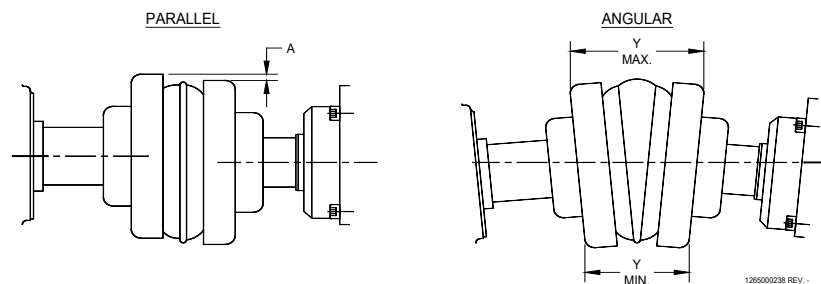

FIGURE 6

## ELECTRICAL INSTALLATION

---

The size of the motor selected should meet the requirements of the operating conditions. A change in conditions (for example, higher viscosity, higher product specific gravity) can overload the motor. For technical assistance regarding operating condition changes, please contact Fristam Pumps.

Have an electrician connect the motor using sound electrical practices. Ensure that proper motor overload protection is provided.

## WATER FLUSH INSTALLATION

---

**FIGURE 7**

Set up the water flush for the double mechanical seal as shown. **Use only 3-12 gallons per hour of water at a pressure of 1-2 PSI.** Excessive seal pressure and/or flow rate through the product seal cavity may cause increased seal wear and shorten seal life.

Pipe the exit side of the water flush with 2-5 feet physical height of tubing. This ensures that some water is always in the center seal and the seal never runs dry.

It is desirable to have the flush water on the outlet side visible. This allows an easy check to see that the flush water is on and also if the seal is functioning properly. In a malfunctioning seal the flush water will disappear, become discolored, or show an unusual increase in flow. If these conditions exist, check the seal and replace if necessary.

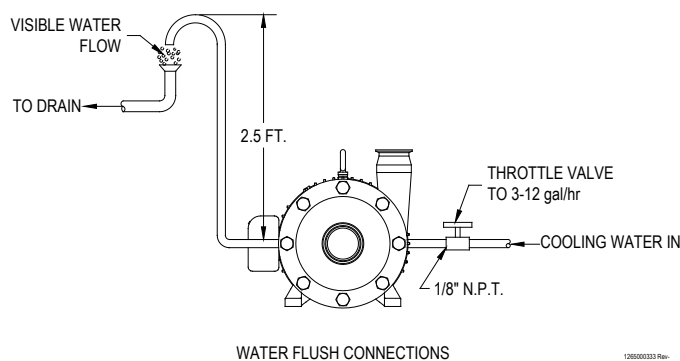

## START-UP INSTRUCTIONS

---

- Remove any foreign matter that may have entered the pump. Do not use the pump to flush the system.
- Before adding oil to the bearing block check the oil drain pipe and cap to make sure they are both properly tightened to avoid any oil leakage from the bearing block. Fill the bearing block with oil to the center of the sight glass on the side of the bearing block (see pages 4 & 5).
- Make sure the pump is flooded with product before start-up. **The pump must not run dry, even momentarily.**
- Make sure the pump is running in the proper direction. The motor fan must turn clockwise when looking at the end of the motor.

## FM3 (HP3) SEAL ASSEMBLY

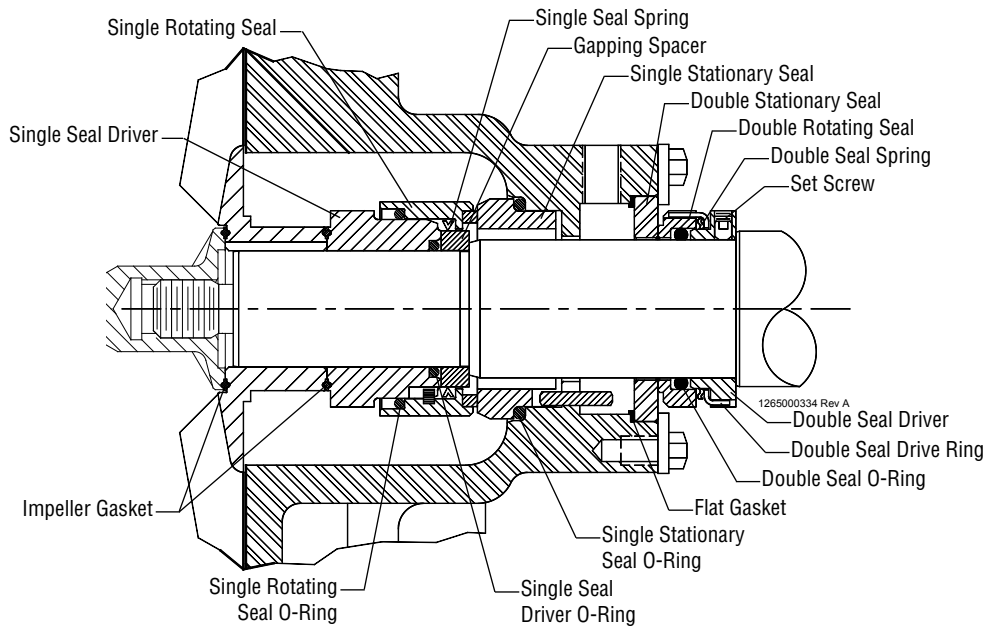

Description	Material	Qty.	Part No.
Single Seal Driver	SS	1	1224000010
Single Rotating Seal	SS/Silicon Carbide Insert	1	1810600084
Single Seal Spring	-	1	1820000025
Gapping Spacer (7.4mm)	SS	1	1224000039
Gapping Spacer (7.7mm)			1224000049
Gapping Spacer (8.0mm)			1224000038
Single Stationary Seal	Silicon Carbide	1	1815600002
Double Stationary Seal	Ceramic	1	1815600093
Double Rotating Seal	Carbon	1	1810600056
Double Seal Spring	-	1	1820000016
Set Screw	-	2	1101000112
Double Seal Driver	SS	1	1811000023
Double Seal Drive Ring	SS	1	1811000027
Double Seal O-Ring	Viton	1	1180000329
	EPDM		1180000348
Flat Gasket	Viton	1	1181000047
	EPDM		1181000147
Single Stationary Seal O-Ring	Viton	1	1181000099
	EPDM		1181000146
Single Seal Driver O-Ring	Viton	1	1180000344
	EPDM		1180000151
Single Rotating Seal O-Ring	Viton	1	1180000030
	EPDM		1180000247
Impeller Gasket	Viton	2*	1181000097
	EPDM		1181000145

\* Quantity may vary

## FM5 (HP4) SEAL ASSEMBLY

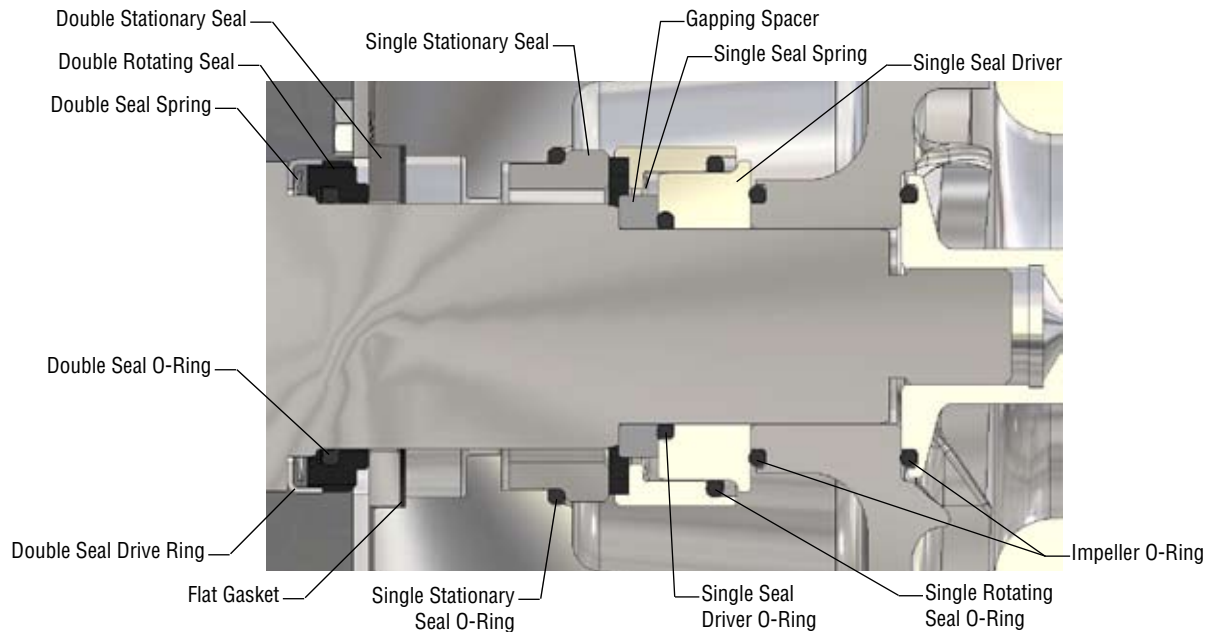

Description	Material	Qty.	Part No.
Single Seal Driver	SS	1	1811000035
Single Rotating Seal	SS/Silicon Carbide Insert	1	1810600099
Single Seal Spring	-	1	1820000028
Gapping Spacer (7.6mm)	SS	1	1224000087
Gapping Spacer (7.8mm)			1224000088
Gapping Spacer (8.0mm)			1224000089
Gapping Spacer (8.2mm)			1224000090
Gapping Spacer (8.4mm)			1224000091
Single Stationary Seal	Silicon Carbide	1	1815600095
Double Stationary Seal	Carbon	1	1815600096
Double Rotating Seal	Carbon	1	1810600100
Double Seal Spring	-	1	1820000028
Double Seal Drive Ring	SS	1	1811000036
Double Seal O-Ring	Viton	1	1180000030
	EPDM		1180000247
Flat Gasket	Viton	1	1181000140
	EPDM		1181000162
Single Stationary Seal O-Ring	Viton	1	1180000253
	EPDM		1180000278
Single Seal Driver O-Ring	Viton	1	1180000329
	EPDM		1180000348
Single Rotating Seal O-Ring	Viton	1	1180000233
	EPDM		1180000366
Impeller O-Ring	Viton	2*	1180000030
	EPDM		1180000247
* Quantity may vary			

## PARTS LIST

Description	Qty	Model		Description	Qty	Model	
		FM3	FM5			FM3	FM5
Cover Nut	8	1103000050	1103000012	Bearing Cover Bolt	8*	1101000096	1101000011
Cover Washer	8	1104000022		Front Bearing Cover	1	1303000008	1303000013
Cover	1	1493620000	1498620000	Front Bearing Cover O-Ring	1	1180000148	1180000748
Cover O-Ring	1*	1180000330	1180000587	Snap Ring	1	1148000005	1148000031
Impeller Nut	1	1954000005	1954000036	Front Bearing	1	1173000012	1173000029
Impeller (First Stage)	1	1493630171	1498630000	Shaft (1-Stage)	1	1340000008	1340000013
Impeller (Second, Third & Fourth Stage)	1*	1493630187	1498630001	Shaft (2-Stage)		1340000009	1340000012
Stage Bushing	1*	1224000048	N/A	Shaft (3-Stage)		1340000010	N/A
Diffuser	1*	1493610001	1498610001	Shaft (4-Stage)		1340000011	N/A
Housing Stud (1-Stage)	8	1103000011	1103000066	Coupling Key	1	1315000008	1315000041
Housing Stud (2-Stage)		1103000009	1103000065	Guard	2	1936000030	1936000135
Housing Stud (3-Stage)		1103000007	N/A	Guard Screw	4	1102000000	
Housing Stud (4-Stage)		1103000005	N/A	Drain Plug Cap	1	1226000007	
Housing	1	1493610000	1498610000	Drain Plug Nipple	1	1226000006	
Water Pipe	2	1910000007		Sight Glass	2	1248000019	
Retaining Ring	1	1148000023	1148000030	Bearing Block	1	1310600038	1310600108
Retaining Ring Bolt	4	1101000086		Vent Cap	1	1248000007	1248000013
Impeller Key (1-Stage)	1	1315000021	1315000036	Vent Cap Cover	1	1248000009	N/A
Impeller Key (2-Stage)		1315000006	1315000035	Rear Bearing	2	1173000036	1173000030
Impeller Key (3-Stage)		1315000022	N/A	Bearing Lockwasher	1	1104000016	1104000058
Impeller Key (4-Stage)		1315000007	N/A	Bearing Locknut	1	1306000005	1306000074
Housing Lockwasher	4	1104000006		Rear Bearing Cover O-Ring	1	1180000149	1180000747
Housing Bolt	4	1101000097	1101000037	Rear Bearing Cover	1	1303000009	1303000014
Front Labyrinth Seal	1	1812000023	1812000037	Rear Labyrinth Seal	1	1812000023	1812000038

\* Quantity may vary

# FM5 EXPLODED PUMP HEAD ASSEMBLY

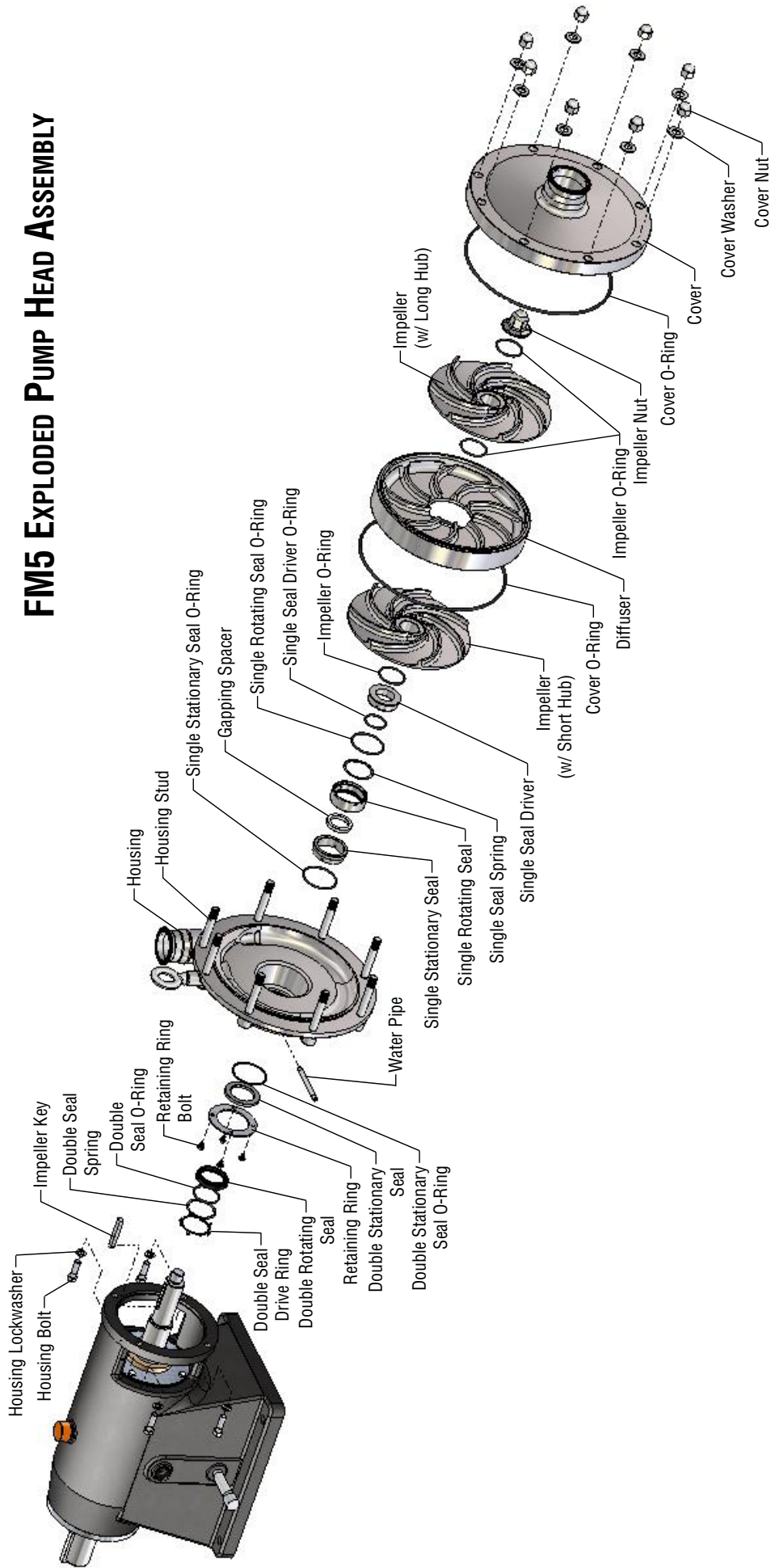

# FM3 EXPLODED PUMP HEAD ASSEMBLY

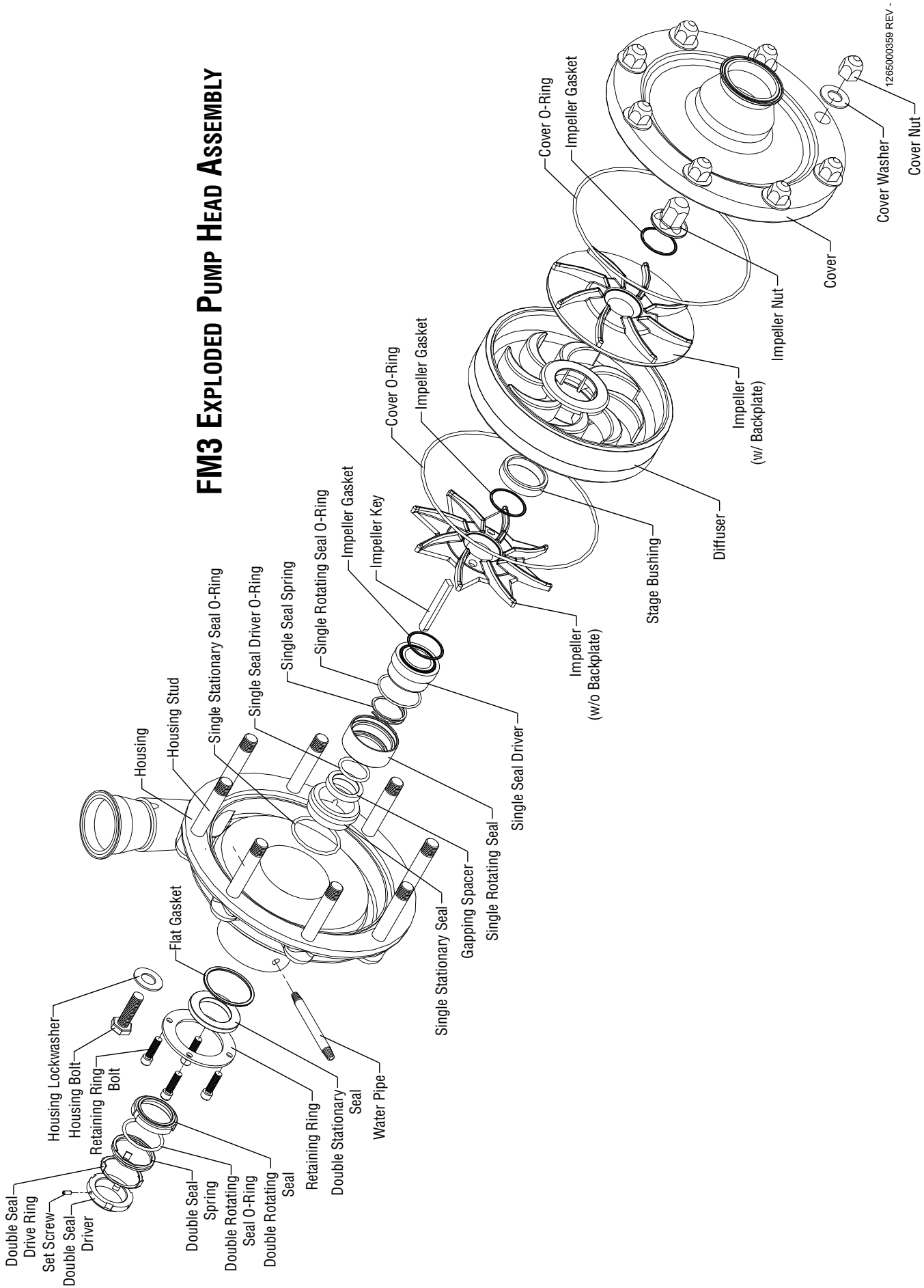

# EXPLODED BEARING BLOCK ASSEMBLY

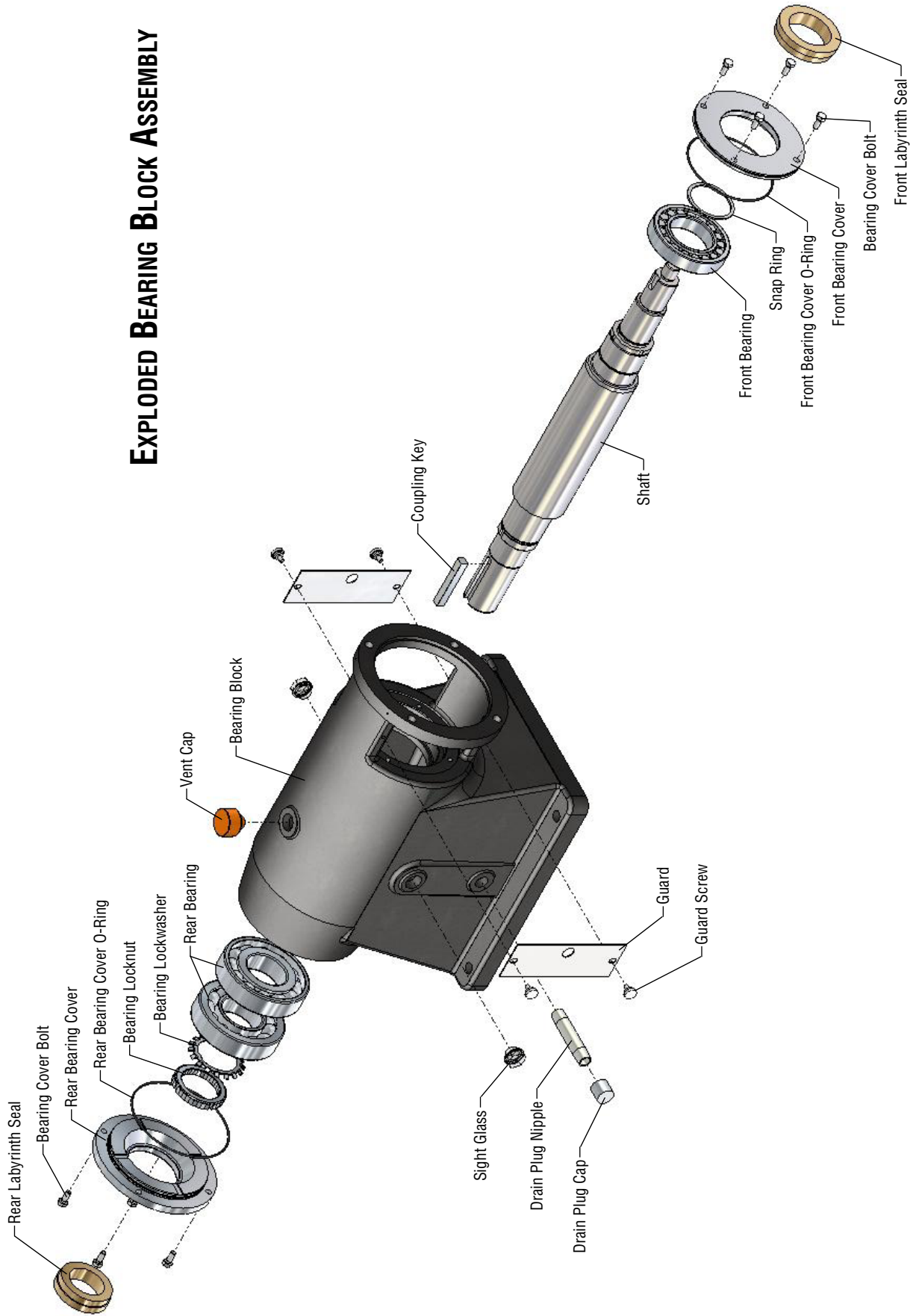

## PUMP HEAD DISASSEMBLY

**FIGURE 8**

Remove the cover and discard the o-ring.

Place a chain wrench on the shaft to prevent it from rotating. Remove the impeller nut and discard the o-ring or gasket.

Remove the impeller(s) and diffuser(s) and discard the o-ring(s) and gasket(s). **FM3 Only: Be careful not to damage the carbon bushing inside the diffuser(s) during removal.**

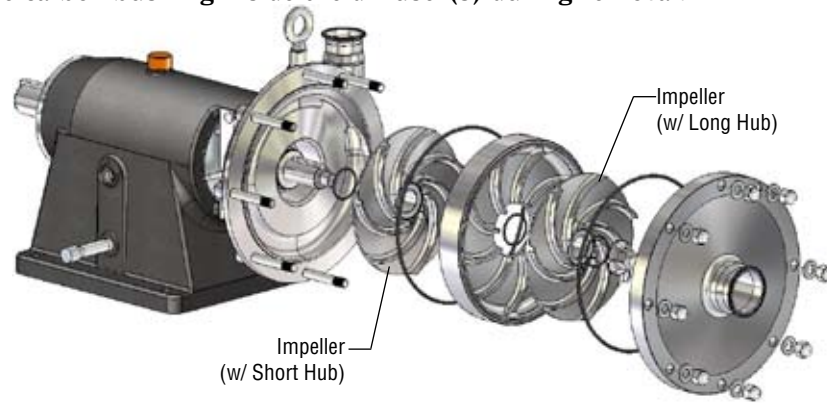

**FIGURE 9**

Remove the single seal components and discard the single rotating seal, spring, stationary seal and o-rings. **Note: Do not discard the single seal driver and gapping spacer.**

Remove the guards.

Remove the water pipes.

**FIGURE 10**

Remove the housing. Remove the retaining ring from the back of the housing.

Remove the double seal components and discard the double rotating seal, stationary seal, flat gasket, spring and o-rings.

**Note: Do not discard the retaining ring, bolts or double seal drive ring.**



## PUMP HEAD ASSEMBLY

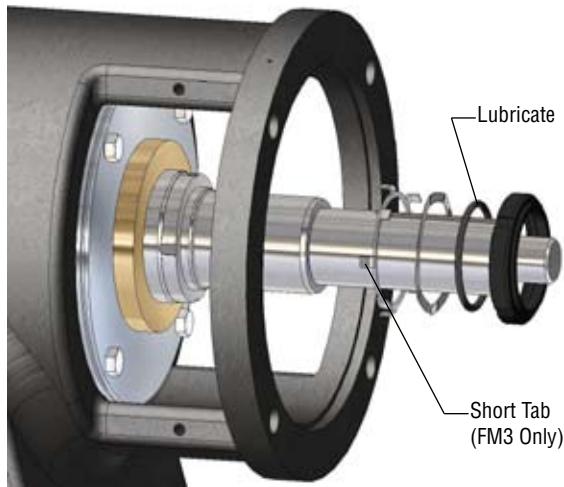

**FIGURE 11**

Install the double seal drive ring making sure to slide the tabs on the ring into the slots on the shaft. **FM3 Only: The shorter tabs on the seal driver slide into the shaft slots.**

Install the spring, o-ring and the double rotating seal. Be sure to slide the tabs on the drive ring into the slots in the rotating seal.

**FIGURE 12**

Install the flat gasket, double stationary seal and retaining ring. Use a torque wrench to tighten the retaining ring bolts.

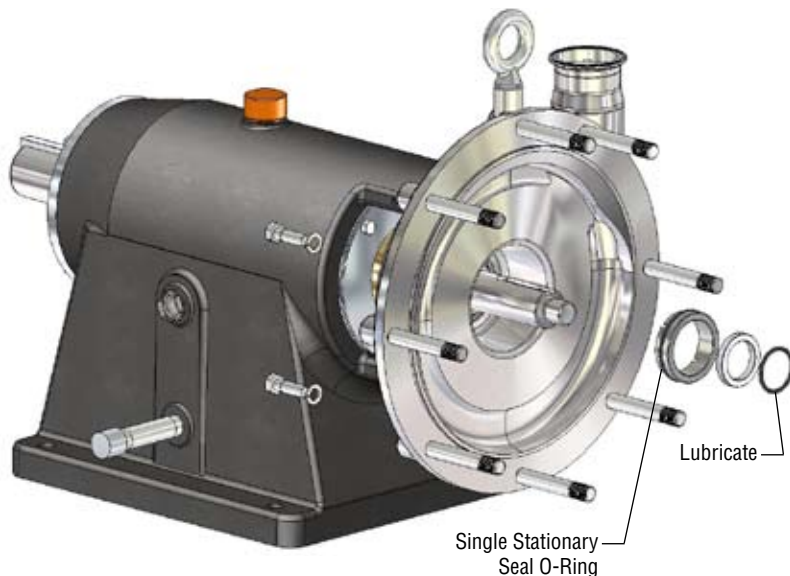
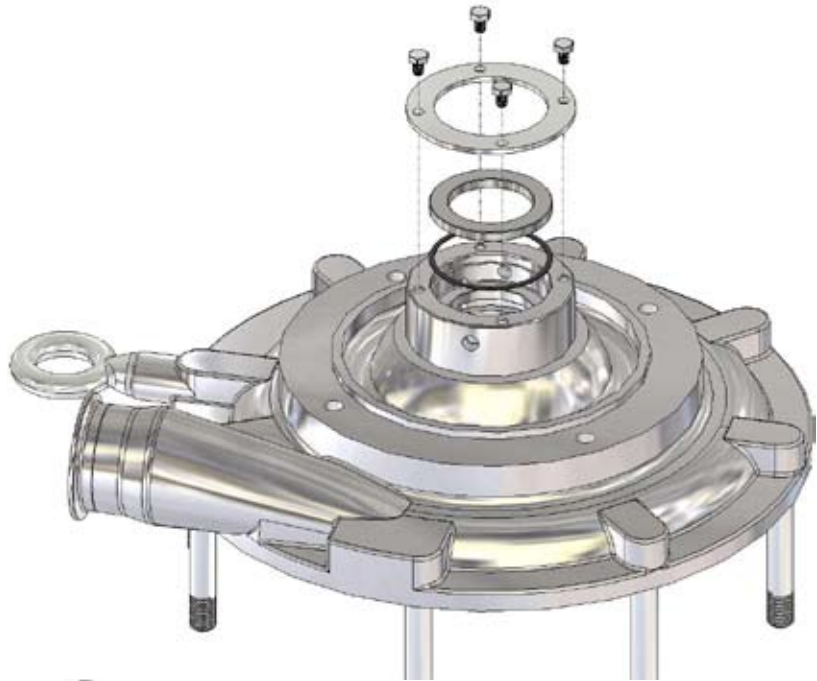

**FIGURE 13**

Install the housing. Use a torque wrench to tighten the housing bolts.

Install the single stationary seal o-ring onto the single stationary seal.

Install the stationary seal making sure to align the pins in the housing with the slots in the seal. Press the seal into the housing until it snaps into place.

Install the gapping spacer.

Install the seal driver o-ring.

**If you replaced the shaft and/or bearings, the impeller gap must be checked before proceeding (Figure 25, page 23).**

**FIGURE 14**

Install the single rotating seal o-ring onto the single seal driver.  
Install the single seal spring behind the pins in the rotating seal.  
Install the driver into the rotating seal making sure to align the pins with the slots.



**FIGURE 15**

Install the single rotating seal and driver assembly.  
Install the water pipes and guards.

**FIGURE 16 (SINGLE STAGE PUMP ONLY)**

Install the impeller key.

Install the impeller o-ring/gasket into the groove on the back of the impeller.

Install the impeller nut o-ring/gasket into the groove on the back of the impeller nut.

Install the cover o-ring into the groove on the back of the cover.

Install the impeller and impeller nut. Place a chain wrench on the shaft to prevent it from rotating while tightening the impeller nut. Use a torque wrench to tighten the impeller nut.

Install the cover. Use a torque wrench to tighten the cover nuts in a cross-tightening pattern.



**FIGURE 16 (MULTI STAGE PUMP ONLY)**

Install the impeller key.

Install the impeller o-rings/gaskets into the groove on the back of the impellers.

Install the impeller nut o-ring/gasket into the groove on the back of the impeller nut.

Install the cover o-ring into the groove on the back of the cover.

Install the short impeller first, then the diffuser, then the long impeller. **FM3 Only: Be careful not to damage the carbon bushing inside the diffuser(s) during installation.**

**Note: The number of impellers and stages will vary, depending on the number of stages in the pump.**

Install the impeller nut and hand tighten. **Note: On multi stage pumps, the cover nuts must be tightened prior to tightening the impeller nut.**

Install the cover. Use a torque wrench to tighten the cover nuts in a cross-tightening pattern.

Place a chain wrench on the shaft to prevent it from rotating while tightening the impeller nut. Use a torque wrench to tighten the impeller nut.

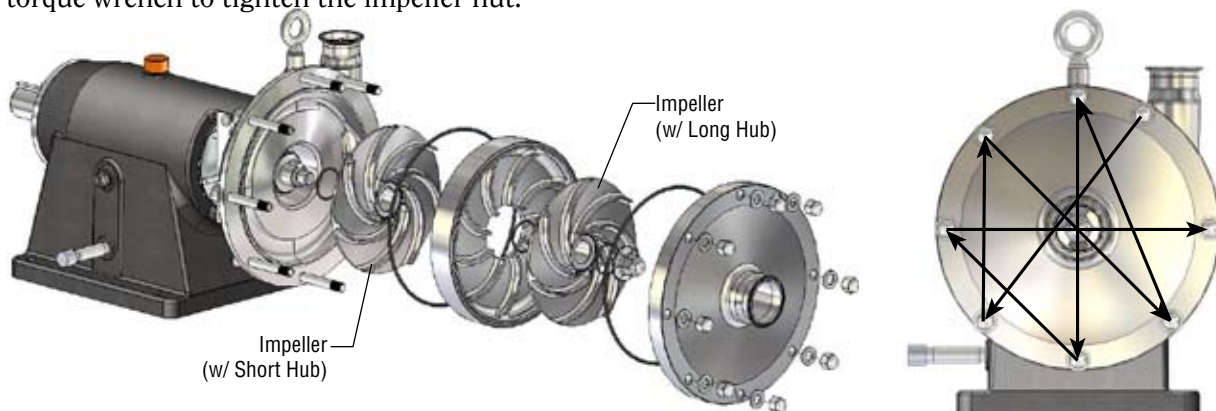

## BEARING BLOCK DISASSEMBLY

Prior to disassembling the bearing block, complete the pump head disassembly (Figure 8-10, page 16).

### FIGURE 17

Place an oil pan below the drain plug. Remove the drain plug cap and drain the oil. Replace the drain plug.

Remove the bearing covers and discard the o-rings. **FM3 Only: Remove the double seal driver from the shaft prior to removing the front bearing cover.**

Remove the snap ring.



### FIGURE 18

Tap on the threaded end of the shaft with a soft-faced hammer to remove the shaft assembly. **Support the shaft during removal so that it doesn't become damaged.**

Remove the outer race of the front bearing.



### FIGURE 19

Straighten the bent bearing lockwasher tab and remove the bearing locknut and washer.

Remove the two rear bearings by pressing them off of the shaft.

Remove the inner race of the front bearing by heating it with a torch until it expands and can be slid off.

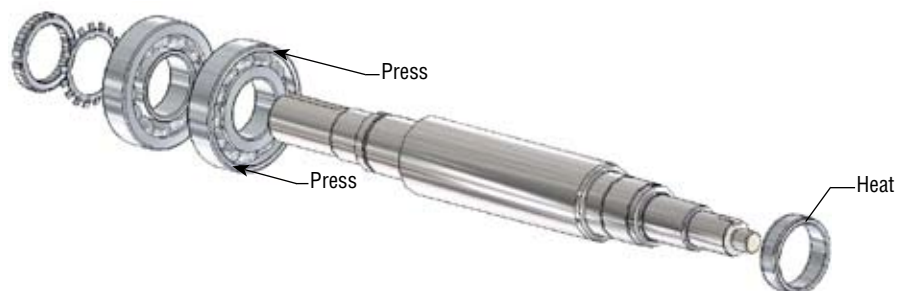

## BEARING BLOCK ASSEMBLY

**FIGURE 20**

Lightly grease the rear bearing step. Heat the rear bearings on a bearing heater to 230°F. Install the bearings in the back-to-back arrangement shown. **Heating the bearings above 250°F will cause damage.**



**FIGURE 21**

Install the bearing lockwasher and locknut. Use a torque wrench to tighten the locknut. Bend one of the lockwasher tabs into a slot on the locknut.



**FIGURE 22**

Lightly grease the front bearing step. Heat the inner race of the front bearing on a bearing heater to 230°F. Install the inner race.



**FIGURE 23**

Press the outer race of the front bearing into the bearing block.

Install the shaft assembly into the bearing block. Press or tap on the outer race of the rear bearing while supporting the front end of the shaft. **Do not press on the shaft or on the inner race of the rear bearing.**



**FIGURE 24**

Install the snap ring.

To replace the labyrinth seals in the front or rear bearing cover: Press the seal out of the cover. Press the new seal in with the drain hole in the downward position. Lubricate the inside o-rings on the seals.

Install the front and rear bearing covers. Use a torque wrench to tighten the bolts.

Remove the vent cap and fill the bearing block with oil to the center of the sight glass.

**FM3 Only:** Prior to assembling the pump head, install the double seal driver. Use a torque wrench to tighten the set screw in the seal driver.

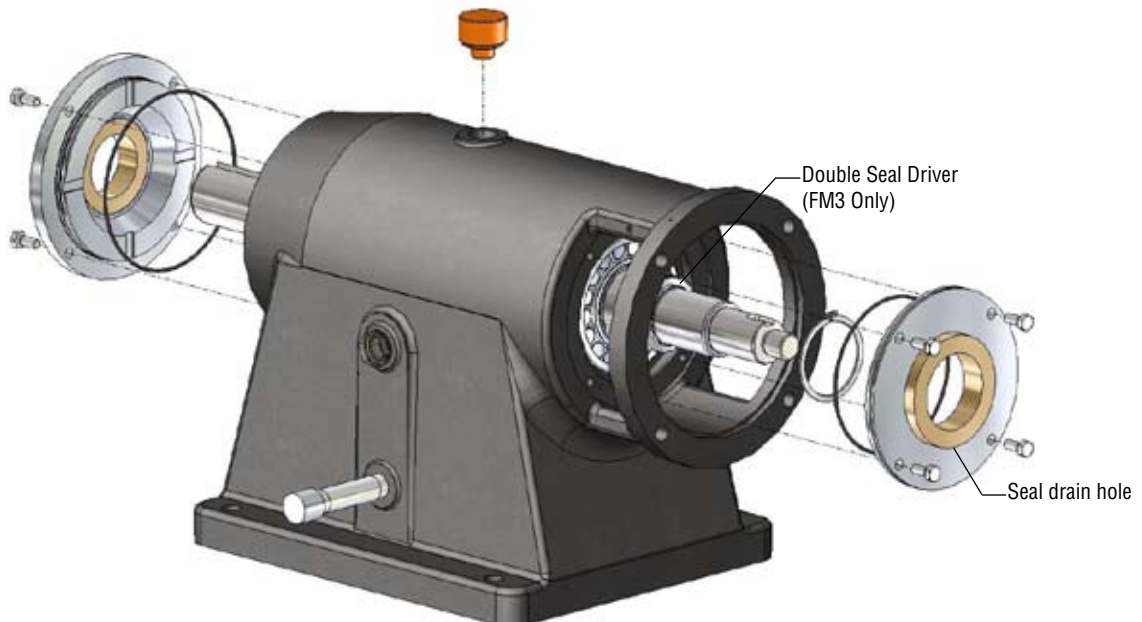

## CHECKING THE IMPELLER GAP

The impeller gap must be checked if the shaft and/or bearings have been replaced.

### FIGURE 25 (SINGLE STAGE PUMP ONLY)

Install the single seal driver and impeller key.

Install the impeller o-ring/gasket into the groove on the back of the impeller.

Install the impeller nut o-ring/gasket into the groove on the back of the impeller nut.

Install the impeller.

Place a chain wrench on the shaft to prevent it from rotating while tightening the impeller nut. Use a torque wrench to tighten the impeller nut.

Measure the gap between the impeller and pump housing using feeler gages. If the gap is incorrect, the gapping shim must be changed to one of a different width.

Once the gap is correct, remove the impeller nut, impellers, impeller key and single seal driver.

Resume pump assembly (Figure 14-16, page 18-19).

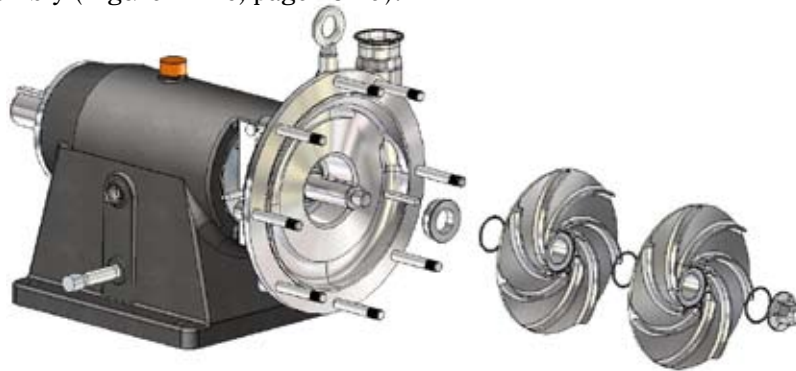

### FIGURE 25 (MULTI STAGE PUMP ONLY)

Install the single seal driver and impeller key.

Install the impeller o-rings/gaskets into the groove on the back of the impellers.

Install the impeller nut o-ring/gasket into the groove on the back of the impeller nut.

Install the short impeller first, then the long impeller(s).

Place a chain wrench on the shaft to prevent it from rotating while tightening the impeller nut. Use a torque wrench to tighten the impeller nut.

Measure the gap between the impeller and pump housing using feeler gages. If the gap is incorrect, the gapping shim must be changed to one of a different width.

Once the gap is correct, remove the impeller nut, impeller, impeller key and single seal driver. Resume pump assembly (Figure 14-16, page 18-19).

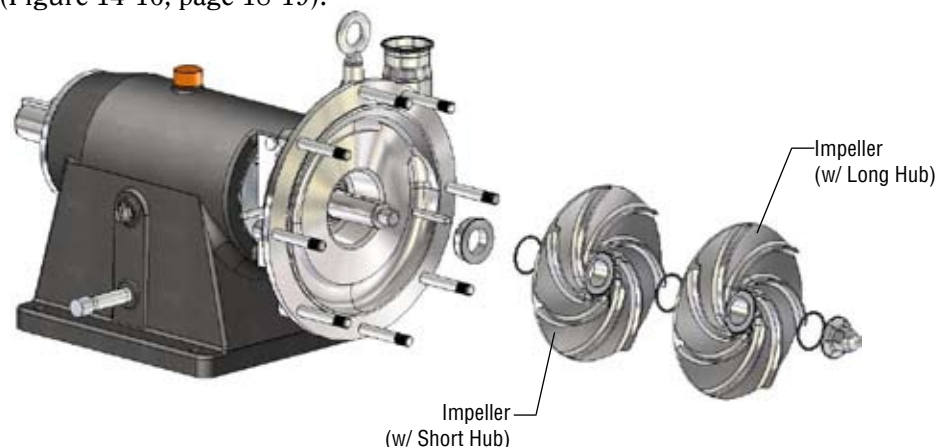

## **NOTICE OF TERMS, WARRANTY PROVISIONS INCLUDING DISCLAIMERS, CLAIMS AND LIMITATION OF LIABILITY**

Prices and all terms and conditions of sale are established in current price sheets and are subject to change without notice. All orders are subject to acceptance by Fristam Pumps.

Each Fristam Pumps item is warranted to be free from manufacturing defects for a period of one (1) year from the date of shipment, providing it has been used as recommended and in accordance with recognized piping practice, and providing it has not been worn out due to severe service, such as encountered under extremely corrosive or abrasive conditions.

*THIS WARRANTY IS EXPRESSLY IN LIEU OF ANY OTHER WARRANTIES EXPRESSED OR IMPLIED, INCLUDING BUT NOT LIMITED TO, ANY IMPLIED WARRANTY OF MERCHANTABILITY OR FITNESS FOR PARTICULAR PURPOSE. ALL OTHER WARRANTIES WHATSOEVER, EXPRESSED OR IMPLIED BY LAW OR OTHERWISE, ARE HEREBY EXCLUDED.*

All claims must be in writing and mailed or delivered by purchaser within thirty (30) days after purchaser learns the facts upon which such claim is based. Any claim not made in writing and within the time period specified above shall be deemed waived.

*PURCHASER'S SOLE AND EXCLUSIVE REMEDY AND FRISTAM PUMPS MAXIMUM LIABILITY FOR CLAIMS ARISING HEREUNDER OR FOR NEGLIGENCE FOR ANY AND ALL LOSSES AND DAMAGES RESULTING FROM ANY CAUSE SHALL BE EITHER THE REPAIR OR REPLACEMENT OF DEFECTIVE ITEMS OR, AT FRISTAM PUMPS' OPTION, THE REFUND OF THE PURCHASE PRICE FOR SUCH ITEMS. IN NO EVENT, INCLUDING IN THE CASE OF A CLAIM FOR NEGLIGENCE, SHALL FRISTAM PUMPS BE LIABLE FOR INCIDENTAL OR CONSEQUENTIAL DAMAGES, INCLUDING LOSS OF PROFITS.*

No person, including any representative, employee or agent of Fristam Pumps, is authorized to assume on behalf of Fristam Pumps any liability or responsibility in addition to or different from that described in this provision. Any and all representations, promises, warranties or statements that are in addition to or different from the terms of this provision are of no force or effect.

If any provision of this Notice is held to be invalid, such provision shall be severed and the remaining provisions shall continue to be in force.



© Copyright 2008 - Fristam Pumps USA Limited Partnership  
Drawing # 1250000012 Rev Updated 1/15/08  
Part # 1050000035  
Visit [www.fristam.com](http://www.fristam.com) for a current list of literature.

2410 Parview Road • Middleton, WI 53562-2524  
1-800-841-5001 • 608-831-5001  
[www.fristam.com](http://www.fristam.com)  
Email: [fristam@fristampumps.com](mailto:fristam@fristampumps.com)